

DISCOVERY OF COMPLEX MODEL IMPLEMENTATION PATTERNS IN SOURCE CODE

Linas Ablonskis, Lina Nemuraitė

*Kaunas University of Technology, Department of Information Systems
Studentų St. 50, LT-51368 Kaunas, Lithuania
e-mail: linas.ablonskis@ktu.lt, lina.nemuraite@ktu.lt*

Abstract. We present a method for discovering complex model implementation patterns in a hand written program code. A model implementation pattern is understood as a repeatedly used humanly meaningful transformation from a set of model elements to a piece of corresponding program code. Complex model implementation patterns are composed from atomic model implementation patterns treated as black boxes. We use the same definition of model implementation pattern for recognizing implementation patterns and generating program code. The method is applied for automated configuring a program code generator.

Keywords: complex implementation pattern, atomic implementation pattern, implementation pattern recognition, model to code transformation, program code generator configuration, MDA.

1. Introduction

In Model Driven Architecture (MDA) [1] related software development, program code generators are used to automatically produce program code from program models. In order to work, program code generators must be provided with program code templates and template application rules. Currently all these configuration data must be written by hand, which is a labor intensive process [2] requiring a lot of expertise to execute correctly [3]. We have proposed a program code generator that can configure itself automatically by recognizing the patterns that human has used to write a partial program code and exploit those patterns to generate program code for yet unimplemented model elements [4]. In our previous work we have created an algorithm that allows recognition of simple, atomic model implementation patterns [5]. In this work we describe a method that allows defining and recognizing complex model implementation patterns composed from atomic model implementation patterns described earlier [5].

The remainder of this paper is structured as follows: in Section 2 we present related works; in Section 3 we present models used to express program model and code together with atomic and complex model implementation patterns, called atomic and complex transformations; in Section 4 we present an algorithm for detecting complex transformations in a program code; Section 5 is devoted for method testing; and finally in Section 6 we provide conclusions and outline the future work.

2. Related works

Model driven development has become the common practice of creating software related artifacts. The main principles of model driven development are separation of concerns and raising level of abstraction. A program code generator is the definitive component of model driven development chain. The program code generation is strictly separated from other levels of MDA and can be performed from such artifacts as ontologies, business process models, business rules, domain models, or design models [6–10]. When related techniques are applied to produce one kind of models from other kind of models, the process is known as transformation [11]. Program code generation intrinsically depends on technology and domain changes; therefore, it is not efficient in quickly changing world. Currently, researchers are looking for more efficient ways of creating program code generators e.g. using meta-programming [12] or domain specific languages [13]. Our idea for improving program code generation is to separate transformations that are used to generate program code from the actual programming language that the generated program code must be expressed in. Also, the manner of program model traversal used for generating program code in our method differs from conventional approaches because we use formal concept analysis to select the sets of model elements that can be implemented by an application of a specific pattern.

Our method of model implementation pattern recognition in a program code is inspired by works in

the area of design pattern recovery. Design patterns [14] are reusable solutions to common software engineering problems modeled by a certain composition of software artifacts. Design pattern recovery methods find instances of design patterns in a program code and are primarily used to assist program comprehension.

Some design pattern recovery methods use static analysis of program code to extract available elements and their relationships and dynamic analysis to extract execution traces and call graphs. The data received from static analysis are enriched with data received from dynamic analysis and analyzed by a set of predefined algorithms made to detect a single design pattern [15, 16]. Alternatively, only data from static analysis can be used [17].

A variation [18] is to use graphs for describing design pattern templates and an algorithm that evaluates edge similarity of two graphs [19] for finding correspondences between design pattern templates and a source code element tree. While not published as a design pattern recovery method, a similar approach [20] uses attributed flow graphs to describe both design patterns and program code. The flow graph based descriptions of design patterns are treated as graph grammars and a special algorithm [21] is used to find the places in a program code flow graph that match the flow grammar expressions of design patterns. Design pattern detection can also be considered to be a constraint satisfaction problem where each design pattern provides a constraint on a set of elements and relations that compose it [17]. There are suggestions [22, 23] to use XML based language for describing design patterns and then applying the same principle to detect them.

Since design pattern detection algorithms can be computationally expensive, there is a work that fingerprints design patterns through a set of code metrics (size, filiations, cohesion and coupling) and then uses these fingerprints to quickly reject invalid candidates before employing standard design pattern recovery techniques [24]. This requires a rule engine and an initial source code base for teaching that rule engine. There is also a method that uses decision trees and neural networks for recognizing design patterns through code metrics [25]. The neural networks must be trained by supplying manually evaluated design pattern candidates extracted from sample source code.

Another approach is to describe design patterns with logical formulas that operate on a set of predicates extracted from source code [26]. These predicates describe the existence of various types of elements and relationships in a parsed program code. The predicates extracted from the source code and logical formulas describing design patterns are fed to a logic engine. The advantage of this method is its ability to find non-standard variants of design patterns, as long as they can be logically reduced to a standard form. There is a paper [27] that suggests standardization of logic predicates used for program code analysis as this

would allow making a tool working with a wide variety of programming languages as long as there are suitable extractors for those languages.

Finally, there is a design pattern recovery method that uses formal concept analysis [28] to analyze a set of predicates extracted from program code when detecting design patterns [29]. Predicates describe existence of entities and their relationships. Application of formal concept analysis enables detection of ad-hock design patterns and does not require design pattern definitions. However, results must be manually interpreted by a human.

The direct application of design pattern recovery methods proved to be unsuitable for our needs. Predicates-with-logical-formulas, one-algorithm-per-pattern and graph-subgraph-matching methods require a lot of work for building predicate sets, logical formulas, algorithms or graphs that correspond to artifacts being detected. Code metrics and Artificial Intelligence (AI) based methods are either approximate, or they only use code metrics and AI techniques to quickly reject candidates. Ad-hoc design pattern detection method [29] is unsuitable for our needs as it will detect something that can be viewed as design patterns, but it will always need a human to comprehend the meaning of those design patterns. Also, we wanted to use the same definition of a program model implementation pattern both for pattern recognition in a program code and program code generation, which is not possible with design pattern models used in existing methods for recovery of design patterns. To satisfy our needs, we have created algorithms for model implementation pattern definition and model implementation pattern recognition while taking the inspiration from the graph-subgraph matching based design pattern recovery methods [17, 19].

From the perspective of program code generation, a model implementation pattern, as it is understood in our work, is conceptually equal to the program code template together with template application rules [11]. While the usual way to define program code templates is in a textual form, we define model implementations patterns as transformations from an abstract representation of a program model to an abstract representation of a program code in an effort to make our method a modeling and programming language agnostic. The meta-model of complex model implementation patterns used in our work allows expression of simple blocks, iterators and conditional evaluation matching only the basic expression capabilities of other template languages commonly used for program code generation, such as Velocity [30], XSLT [31], Xpand [32], JET [33], etc. Relatively weak expression capabilities of complex model implementation patterns are partially compensated by the fact that they are built from atomic model implementation patterns, which are defined as black box functions, allowing any complexity inside.

When it comes to program code generation and reverse engineering, there is a method that allows

analyzing generated source code and recognizing templates that were used to generate it, by using the same definition of a program code template for both tasks [34]. The method is independent from source code language; however, it cannot recognize reordered program code and cannot reverse engineer program code directly into the same level of abstraction that it was generated from. Thus it is unsuitable to analyze hand written program code and does not fit our needs.

3. Specifying model implementation patterns

A model implementation pattern describes how a piece of a program model can be expressed in a piece of program code. Thus a model implementation pattern is a transformation from a piece of program model to a piece of program code. From now on we will call complex model implementation patterns as *complex transformations* and simple, atomic model implementation patterns as *atomic transformations*.

The method for definition and recognition of complex transformations presented in this paper is based on our previous work dedicated to definition and recognition of atomic transformations, called basic transformations in the previous paper [5]. Since then we have devised a slightly improved model for definition of atomic transformations and a slightly improved algorithm for detecting instances of atomic transformations in a program code that we will briefly present here.

We represent elements of a program model through instances of *model concepts* and elements of a program code through instances of *code concepts*. Both types of concepts can be joined in respective concept graphs. A concept is an instance of a concept template. Each unique concept template corresponds to some unique concept in a modeling or programming language. An example of modeling language concepts can be taken from Unified Modeling Language (UML) [35]: class, interface, method, etc. An example of programming language concepts can be taken from Java language: package, class, method, loop, conditional branch, etc.

A concept has a set of slots and a set of attributes. Slots are used for building concept graphs and contain references to other concepts in a graph. Attributes are used to store literal values that describe a literal property of the concept. In our previous work we had to split base hierarchies of model concepts into concept, concept-with-name and concept-with-value branches to express name and value attributes. Current model of attributes allows defining the same things and more while retaining single base types of model and code concepts. The new concept meta-model is shown in Figure 1.

Model concept graphs are used to represent models and code concept graphs are used to represent program code. Model concepts and model concept graphs follow the meta-model shown in Figure 2.

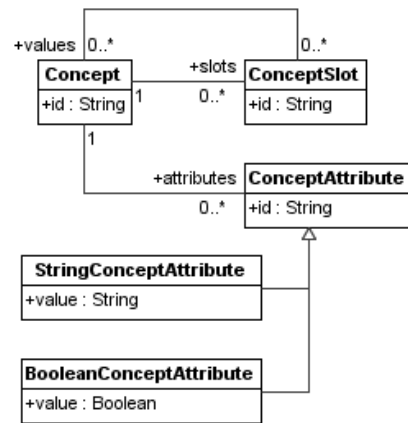

Figure 1. A common part of model and code concept meta-models

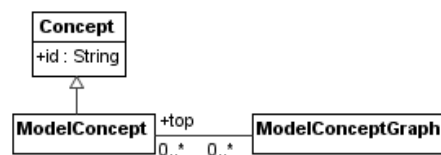

Figure 2. Meta-model of model concepts and model of model concept graphs

A model concept graph is represented by a container that allows accessing top model concepts. Top model concepts are considered to be those that represent top containers in a program model.

Code concepts and code concept graphs follow the meta-model shown in Figure 3.

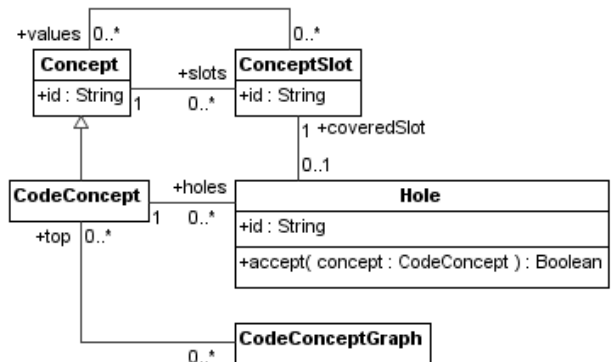

Figure 3. Meta-model of code concepts and model of code concept graphs

Holes are used to specify possible connection points to other code concept graphs. A hole has a unique identifier *id* and a function *accept* that returns if given code concept can be placed into a hole. A code concept graph is represented by a container that allows accessing top code concepts. Top code concepts are considered to be those that represent top containers in a program code.

We describe model implementation patterns through atomic and complex transformations. *Atomic transformations* are designed to describe the basic humanly meaningful mappings of program model

elements into program code elements as black box functions and are discussed in our previous paper under the name of basic transformations [5]. *Complex transformations*, the subject of this paper, are made by composing atomic transformations and are designed to describe complex humanly meaningful mappings of program model elements into program code elements. The requirement for transformations to be humanly meaningful has a twofold purpose. First, it limits the number of possible transformation functions. Second, it allows credible application of transformations for analysis of a hand written program code, because hand written program model implementation in a program code is a result of a humanly meaningful transformation from a program model to a program code.

The meta-model of atomic transformations is shown in Figure 4.

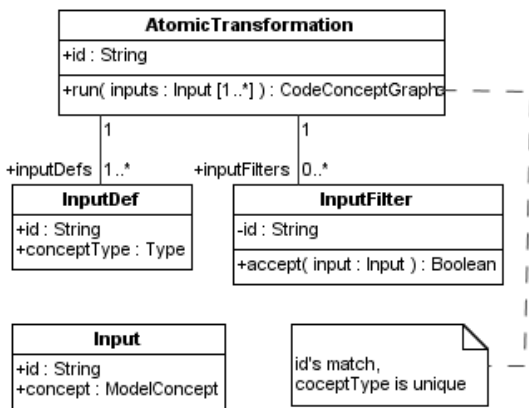

Figure 4. Meta-model of atomic transformations

An atomic transformation function *run* takes a list of inputs and produces a code concept graph with holes. Holes mark points where other code concept graphs may be attached when joining the outputs of several atomic transformations. A list of input definitions *inputDef* tells what number and kind of inputs are accepted by an atomic transformation. A list of input filters *inputFilters* defines additional conditions for valid inputs of an atomic transformation. The atomic transformation function *run* accepts a list of inputs that must follow the list of input definitions and distinguishes individual inputs by the corresponding *id* field. A valid input definition list must have no input definitions with matching *conceptType*; this condition is necessary for correct operation of the algorithm that detects instances of atomic transformations in a program code.

The meta-model of complex transformations is shown in Figures 5–8.

A complex transformation has a list of input definitions *inputDefs* specifying the number and type of model concepts that the transformation accepts. When complex transformation is executed, it is supplied with a list of inputs that match the input definitions. Complex transformation has a list of input filters *inputFilters* that can be used to impose additional

restrictions on valid inputs. Input filters are based on white box condition expressions. Complex transformation also has a body that is a tree of atomic transformation wrappers and control nodes as shown in Figure 6.

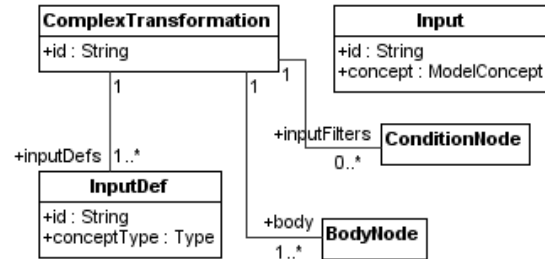

Figure 5. Meta-model of a complex transformation

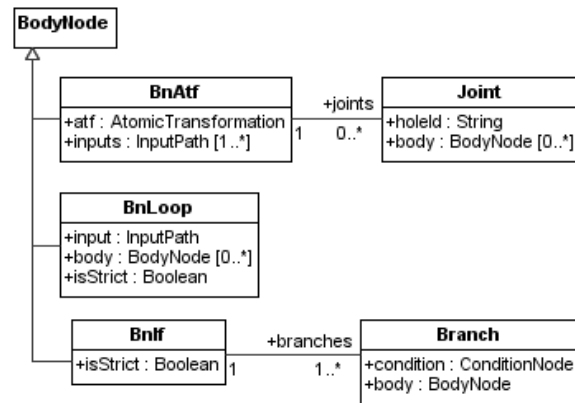

Figure 6. Model of a complex transformation body

An atomic transformation wrapper node *BnAtf* references a single atomic transformation and specifies how to provide the inputs of that atomic transformation from the inputs of host complex transformation. Atomic transformation inputs are provided through a list of input paths, described further in the text. Atomic transformation wrapper also contains a list of *joints* that place other body nodes of complex transformation into holes of code concept graphs produced by atomic transformation functions.

A loop node *BnLoop* takes a list of model concepts provided by a given input path and evaluates its body for each of those concepts. Input paths within loop body can read the value of loop iterator. Strict loops are supposed to iterate at least once, non strict loops can iterate zero times.

A conditional evaluation node *BnIf* has a list of branches that contain conditions. The first branch whose condition is satisfied has its body evaluated. Strict conditional nodes are supposed to evaluate a body of one branch; non strict conditional nodes are allowed to evaluate zero branches.

An input path (Figure 7) allows specifying a sequence of actions for extracting one or more concepts from an input of a complex transformation. They are used to provide inputs of wrapped atomic transformations and in the white box condition expressions.

IpnInput node reads from a given input of a complex transformation and can be followed by *IpnSlot*, *IpnOne* and *IpnFilter*. *IpnSlot* node reads from the given concept slot and can be followed by *IpnSlot*, *IpnOne* and *IpnFilter*. *IpnOne* node selects one concept from the list and can be followed by *IpnSlot*. *IpnFilter* node rejects concepts from a list and can be followed by *IpnOne*. *IpnLoop* selects the current iterator value of a given loop and can be followed by *IpnSlot*. *IpnLoop* must be used only inside the body of the loop it extracts from.

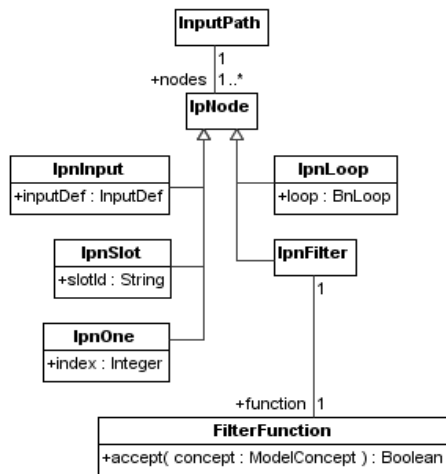

Figure 7. Model of input paths

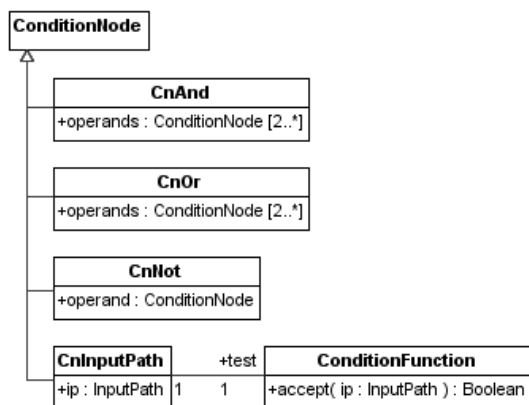

Figure 8. Model of white box conditions

Finally, white box condition expressions (Figure 8) are used for filtering the inputs of complex transformation and branches of conditional evaluation nodes. Leaf nodes of the expression are *CnInputPath* nodes that specify an input path and a condition function on its result. *CnAnd* node corresponds to logical conjunction of its operands, *CnOr* node to logical disjunction and *CnNot* to negation.

4. Detecting complex model implementation patterns

The method for detecting the presence of atomic transformation instances in a program code is described in our previous paper [5]. The algorithm works with code concept trees, but can be trivially improved to operate on code concept graphs by adding the support for graph cycle avoidance with a simple trace of nodes being visited. In our current work, we use the improved version. Detections of atomic transformation instances correspond to the model shown in Figure 9. Fields of an atomic transformation instance detection have the following meaning: *atf* – an atomic transformation, *inputs* – inputs to atomic transformation, *output* – output of atomic transformation and *matches* – a list of code concepts from the given code concept graph that matched top code concepts of an atomic transformation output.

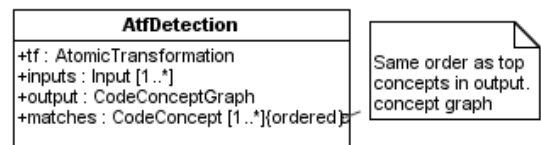

Figure 9. Model of an atomic transformation instance detection

This way, instances of *AtfDetection* specify the atomic transformation instance detected and the starting position of a detection in a given code concept graph.

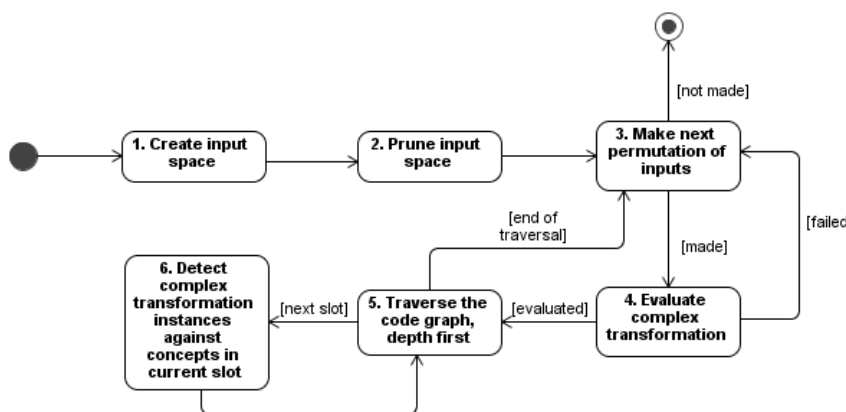

Figure 10. An algorithm for detecting how complex transformation relates parts of program model with parts of program code

By exploiting the ability to detect instances of atomic transformations in a program code, we can also detect instances of complex transformations. For this, we take complex transformations one by one and detect how they relate parts of given program model with parts of given program code. The outline of the algorithm for detecting complex transformation instance is shown in Figure 10.

Given a model concept graph, we compose a list of all model concepts present and create an input space for a given complex transformation by composing lists of model concepts that satisfy input definitions and pass input filters (Figure 10, action 1). Then we prune the input space by removing inputs for which we can prove that using those inputs will result in a failure of complex transformation evaluation in every possible scenario (Figure 10, action 2). To prune the input space, a complex transformation is roughly emulated and all members of a given input space are verified against input paths found in complex transformation body. If some member of an input space fails an input path at every possible execution scenario of a complex transformation, it is thrown out.

Once the input space is pruned, we start making permutations of inputs (Figure 10, action 3) and for each permutation we evaluate a complex transformation (Figure 10, action 4). Evaluation of a complex transformation can fail. Failure can happen if at some point of complex transformation evaluation it is found that some input path cannot be evaluated due to incompatible model structure or if some input path, when evaluated, produces model concept that is not accepted by a filter of atomic transformation used in some body node. If evaluation of a complex transformation fails against some permutation of inputs, we skip that permutation and move on to the next one.

If evaluation of a complex transformation succeeds, the result is a graph of nested atomic transformation instances that corresponds to a model shown in Figure 11.

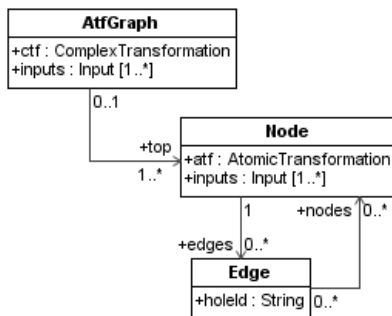

Figure 11. Model of atomic transformation instance graphs

AtfGraph represents an instance of an *atomic transformation instance graph* where field *ctf* points to a complex transformation whose instance is described by a graph and field *inputs* stores inputs of that complex transformation instance. A graph has a set of nodes represented by a class *Node*. Each node points to an atomic transformation through field *atf* and field

inputs stores inputs of that atomic transformation. Each node has a list of edges represented by a class *Edge*. Each edge corresponds to a hole in an atomic transformation represented by a source node. The *id* of that hole is stored in a field *holeId*. Each edge points to a list of destination nodes.

An atomic transformation instance graph represents a partially evaluated complex transformation with loops unrolled, conditional branches selected and input paths evaluated. Since we can detect instances of atomic transformations in code concept graphs, any code concept graph together with a set of atomic transformation instances detected in that graph can be used to detect complex transformation instances represented by atomic transformation instance graphs.

Once an evaluation of a given complex transformation produces an atomic transformation instance graph G , the complex transformation instance detection process starts traversing the code concept graph, that represents a given program code (Figure 10, action 5). Each step of traversal produces a set of sibling code concepts S . For each S , a set B of atomic transformation instance detections is composed, where each atomic transformation instance detection $b \in B$ starts with code concepts from S . Then a list M of atomic transformation instance detections from B with related coverage values is composed for every top node of G .

Let us define A as a set of all nodes in G . To compute the coverage of some $a \in A$ over some $b \in B$, a is overlaid on top of b and the best possible match of the atomic transformation instance graphs that start with a and b is found. Once the match is found, the graph that starts with a is taken and the coverage is computed by dividing the number of matched nodes by the number of nodes in the graph. This yields the coverage value in range $[0; 1]$, where 0 means that there is no match between the graphs spanned by a and b and 1 means that there is a total match. The algorithm for that is shown in Figure 12.

Once a list M of atomic transformation instance detections from B together with related coverage values is computed for every top node of G , we take all those lists and make permutations from their items. In each permutation there are no duplicate $b \in B$. We register each permutation as a detection of a complex transformation instance in the position specified by the positions of b 's (Figure 10, action 6). The coverage of each detection is calculated by taking a total number of matched nodes in the graphs spawned by related a 's, and dividing that number by the number of nodes in those graphs. This yields the coverage value in range $[0; 1]$ where 0 means that there is no complex transformation instance detection at the given position of a given code concept graph and 1 means that the complex transformation was fully detected at the given position of a given code concept graph. The algorithm for that is shown in Figure 13.

```

def checkMatch(node : Node, atfd : AtfDetection) : Match = {
  val theMatch = new Match(node = node, atfd = atfd);
  if( node.atf.id != atfd.atf.id) return theMatch;
  val inputsMatch = check if items from node.inputs matches items in atfd.inputs;
  if( !inputsMatch ) return theMatch;
  theMatch.coverage.raw = 1;
  for( edge <- node.edges ) {
    val hole = the hole in atfd.output having the same id as edge.holeId;
    val holeConcepts = concepts in a given code concept graph that fall into the hole;
    val holeAtfds = atomic transformation instance detections that start with holeConcepts,
    except those that rely on concepts consumed by the atfd;
    var matchLists = List[List[Match]]();
    for( dstNode <- edge.nodes ) {
      var matchList = List[Match]();
      for( holeAtfd <- holeAtfds ) {
        val holeAtfdMatch = check(dstNode, holeAtfd);
        if( holeAtfdMatch.coverage.raw > 0 )
          matchList = matchList :+ holeAtfdMatch;
      }
      if( matchList.size > 0 ) matchLists = matchLists :+ matchList;
    }
    bestMatchPerm = make permutations from the items in match lists; each permutation does not
    contain two matching atomic transformation instance detections; find permutation with the
    best unit coverage;
    theMatch.matches = theMatch.mathes ++ bestMatchPerm;
  }
  calculate the total raw and unit coverage of the match by using coverage information from
  the sub matches and total size of the sub graph that starts with the node;
  return theMatch;
}

```

Figure 12. The algorithm for computing the match between a node of an atomic transformation instance graph and atomic transformation instance detection

```

val atfds : List[AtfDetection]() = ...;
val graph : AtfGraph = ...;
var matchLists = List[List[Match]]();
for( node <- graph.top ) {
  var matchList = List[Match]();
  for( atfd <- atfds ) {
    val theMatch = checkMatch(node, atfd);
    if( theMatch.coverage.raw > 0 )
      matchList = matchList :+ theMatch;
  }
  if( matchList.size > 0 ) matchLists = matchLists :+ matchList;
}
val perms = a list of permutations from the items of matchLists where in each permutation
there are no items with matching atomic transformation instance detections;
for( matchPermutation <- perms )
  register a detection from a matchPermutation

```

Figure 13. The algorithm for recognizing the complex transformation instance graph in a given code concept graph with atomic transformation instance detections

A model of complex transformation instance detection is shown in Figure 14.

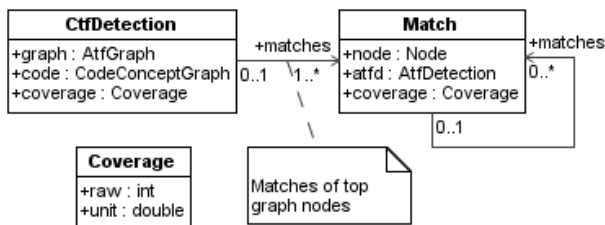

Figure 14. Model of complex transformation instance detections

Complex transformation instance detection stores an atomic transformation *graph* that was detected, a *code* where detection took place, a *coverage*

measurement, and a list of *matches* for top nodes of the graph. Each match stores a *node* of an atomic transformation instance graph and a corresponding atomic transformation instance detection *atfd* together with coverage measurement stored as *coverage* and a list of submatches *matches*. Each coverage measurement is represented by two fields. The field *raw* describes how many nodes (and sub nodes) have been detected to match. The field *unit* stores a normalized coverage value in range [0; 1] computed as *raw/totalNodes* where *totalNodes* is a total number of nodes in an atomic transformation instance graph, or in a case of a single match, a total number of nodes in a sub-graph that starts with the head node of the match.

Each complex transformation detection means that some model concepts in a given program model relate to some code concepts in a program given code by the

algorithm described in the complex transformation and the measure of that relation can be normalized into an interval [0; 1] where 0 means that complex transformation instance was not detected at given point at all, and 1 means that complex transformation instance fully matches program code at a given point. Since a complex transformation represents a complex program model implementation pattern, detection of some complex transformation instances are recognitions of related model implementation patterns in a program source code.

5. Method testing

We have used the method for definition and recognition of complex transformations, described in this paper, to implement an automatically configured program code generator that can detect program model implementation patterns in a partial handwritten source code provided by a human and automatically use those patterns to generate program code for yet unimplemented model elements. The in-depth description of an automatically configured program code generator includes the method for detecting implementation similarity of program model elements and is beyond the scope of this paper.

We have performed the experiment to validate and test the prototype of an automatically configured program code generator. Inherently, the method of complex transformation instance detection got tested as well. The experiment was supplied with the sample sets of atomic transformations (15 items), complex transformations (8 items) and a sample set of model and code concepts, together with transformations from UML models to model concept graphs and bidirectional transformations between Java code and code concept graphs.

The model concept set allowed expression of packages, classes, interfaces, class and interface derivations, class and interface properties, stereotypes and stereotype applications, class and interface operation definitions, primitive and non primitive types and various associations. The code concept set allowed expression of array related definitions and operations; the concept of value assignment; various control flow related concepts; concepts for the definition of program artifacts, such as classes, interfaces, methods, variables, etc; concepts for object oriented programming such as type cast and instance creation; literal value definitions and a type reference concept.

Complex transformations provided several types of mappings from model classes and interfaces to code classes and interfaces with varying levels of information transfer. Atomic transformations provided the primitive mappings between individual types of model elements and related code concept graphs that were necessary to express the complex transformations.

The experiment was supplied with the input model shown in Figure 15.

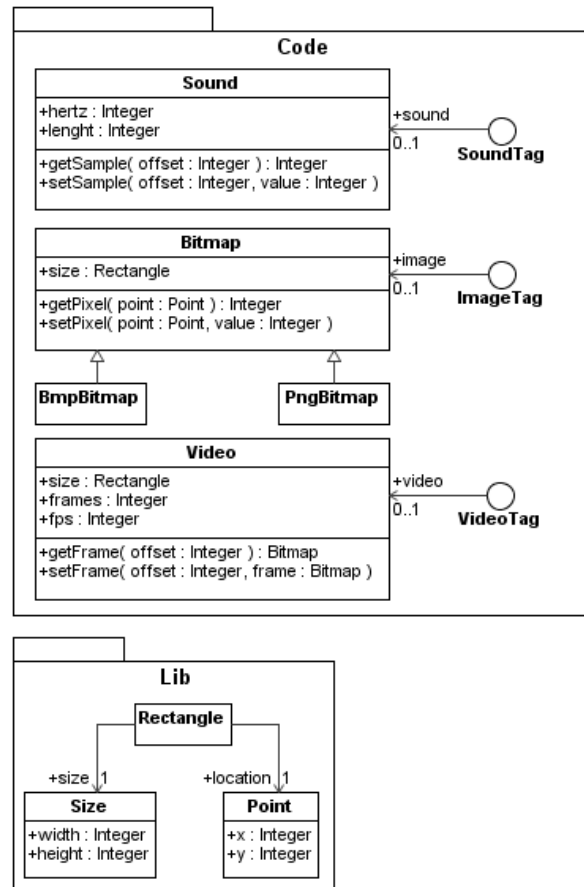

Figure 15. An input model used for experiment

The sample implementation of classes *Sound*, *Point* and interface *SoundTag* were used to drive the configuration of a program code generator and thus were the ones where the recognition of complex transformation instances took place. The implementations of other classes and interfaces were generated by applying the complex transformation whose instance was detected in a related sample implementation of *Sound*, *Point* or *SoundTag*.

The experiment was performed in seven steps. The first step has provided simple POJO (Plain Old Java Object) implementations of the classes *Sound*, *Point* and interface *SoundTag*. The second step added property accessor methods to implementation of *Sound*. The third step added property accessor methods to implementation of *Point*. The fourth step has provided implementation of *Sound* through class and interface pair. The fifth step has provided the implementation of *SoundTag* as interface and interface adapter pair. The sixth step has once again added property accessor methods to previous implementation of *Sound*. And the seventh step has added property accessor methods to the previous implementation of *SoundTag*.

In each step of the experiment the complex transformation instance detection algorithm, described above, has correctly detected appropriate complex transformation instances in the sample implementations of *Sound*, *Point* and *SoundTag*. Since there were

7 steps with 3 sample implementations per step a total of 21 sample pieces of code were examined in respect to a total of 8 complex transformations and the presence of complex transformation instances and the degree of complex transformation instance coverage were correctly detected each time.

6. Conclusions and future work

We have created a method that allows detecting complex program model implementation patterns in a handwritten program code. The method was used in an automatically configured program code generator that can detect program model implementation patterns in a partial handwritten program code and use those implementation patterns to generate program code for yet unimplemented model elements. We have defined program model implementation patterns as humanly meaningful transformations from pieces of program model to pieces of program code and have graded them into atomic and complex where atomic model implementation patterns are black box model-to-code transformation functions and complex model implementation patterns are composed from atomic ones. Our method allows using the same definition of an implementation pattern both for recognitions and program code generation purposes.

While the usual way to define program code generator templates uses a textual form, we define model implementation patterns as transformations from an abstract representation of a program model to an abstract representation of a program code in an effort to make our method of implementation pattern recognition a modeling and programming language agnostic. The meta-model of complex model implementation patterns used in our work allows expression of simple blocks, iterators and conditional evaluations.

In certain cases it may be desirable to use the abbreviated version of a complex transformation for implementation pattern detection and the longer version for program code generation. Addition of such feature would require appending the complex transformation meta-model with artifacts for differentiating between the parts used for complex transformation detection and the parts used for program code generation. On that score, the essence of complex transformation detection algorithm would not change.

Current model of complex transformations cannot express the difference between complex transformation parts where ordering of sibling elements matters and those parts where it does not, thus either one or another must be assumed for the whole complex transformation. Current complex transformation instance detection algorithm assumes that ordering of sibling elements does not matter. Removing this weakness requires adding scope constructs into complex transformation model and supporting those constructs in a complex transformation instance detection algorithm.

References

- [1] **J. Bézivin.** On the unification power of models. *Software and Systems Modeling*, 4(2), 2005, 171–188.
- [2] **R.L. Glass.** Some Thoughts on Automatic Code Generation. *ACM SIGMIS Database*, 27(2), 1996, 16–18.
- [3] **J. Herrington.** Code generation in action. *Manning Publications Co*, 2003.
- [4] **L. Ablonskis.** An approach to generating program code in quickly evolving environments. In *G. A. Papadopoulos, G. Wojtkowski, W. W. Wojtkowski, S. Wrycza, J. Zupancic (Eds.): Information Systems Development: Towards a Service Provision Society*, Springer-Verlag: New York, 2009, 259–267.
- [5] **L. Ablonskis, L. Nemuraitė.** Discovery of model implementation patterns in source code. *Information Technology and Control*, 39(1), 2010, 68–76.
- [6] **A. Čaplinskis, A. Lupeikienė, O. Vasilecas.** Shared Conceptualization of Business Systems, Information Systems and Supporting Software. In *Haav, H.-M.; Kalja, A. (Eds.): Databases and Information Systems II. Fifth International Baltic Conference "Baltic-DB&IS'2002", June 3-6, 2002, Tallinn, Estonia. Dordrecht / Boston / London: Kluwer Academic Publishers*, 2002, 109–120.
- [7] **O. Vasilecas, D. Kalibatienė, G. Guizzardi.** Towards a Formal Method for the Transformation of Ontology Axioms to Application Domain Rules. *Information Technology and Control*, 2009, 38(4), 271–282.
- [8] **O. Vasilecas, S. Sosunovas.** Practical Application of BRTL Approach for Financial Reporting Domain. *Information Technology and Control*, 2008, 37(2), 106–113.
- [9] **T. Skersys.** Business Knowledge-Based Generation of the System Class Model. *Information Technology and Control*, 2008, 37(2), 145–153.
- [10] **A. Armonas, L. Nemuraitė.** Using Attributes and Merging Algorithms for Transforming OCL Expressions to Code. *Information Technology and Control*, 2009, 38(4), 283–293.
- [11] **K. Czarnecki, S. Helsen.** Classification of model transformation approaches. *OOPSLA2003, Workshop on Generative Techniques in the Context of MDA*, 2003 *Anaheim, CA, USA*.
- [12] **R. Damaševičius, V. Štūkys.** Taxonomy of the Fundamental Concepts of Metaprogramming. *Information Technology and Control*, 2008, 37(2), 124–132.
- [13] **J.R. Cordy.** Eating our own dog food: DSLs for generative and transformational engineering. In *GPCE '09: Proceedings of the eighth international conference on Generative programming and component engineering, October 2009*, ACM, 3–4.
- [14] **E. Gamma, R. Helm, R. Johnson, J. Vlissides.** Design Patterns – Elements of Reusable Object-Oriented Software. *Addison-Wesley Publishing Co.*, 1995.
- [15] **D. Heuzeroth, T. Holl, G. Högström, W. Löwe.** Automatic design pattern detection. In *proceedings of the 11th IEEE International Workshop on Program Comprehension*, 2003, 94–103.
- [16] **N. Shi, R.A. Olsson.** Reverse engineering of design patterns from java source code. In *proceedings of the 21st IEEE/ACM International Conference on Automated Software Engineering*, 2006, 123–134.

- [17] **H. Albin-Amiot, P. Cointe, Y.G. Guéhéneuc, N. Jussien.** Instantiating and detecting design patterns: putting bits and pieces together. *In proceedings of the 16th Annual International Conference on Automated Software Engineering*, 2001, 166–173.
- [18] **N. Tsantalis, A. Chatzigeorgiou, G. Stephanides, S.T. Halkidis.** Design pattern detection using similarity scoring. *IEEE Transactions on Software Engineering*, 32(11), 2006, 896–909.
- [19] **V.D. Blondel, A. Gajardo, M. Heymans, P. Senellart, P. Van Dooren.** A measure of similarity between graph vertices: applications to synonym extraction and web searching. *SIAM Review*, 46(4), 2004, 647–666.
- [20] **C. Rich, L.M. Wills.** Recognizing a program's design: a graph-parsing approach. *IEEE Software*, 7(1), 1990, 82–89.
- [21] **D.C. Brotsky.** An Algorithm for Parsing Flow Graphs. *Technical report TR-704, MIT Artificial Intelligence Laboratory*, 1984.
- [22] **Z. Balanyi, R. Ferenc.** Mining design patterns from C++ source code. *In proceedings of the International Conference on Software Maintenance*, 2003, 305–314.
- [23] **J.M. Smith, D. Stotts.** SPQR: Flexible automated design pattern extraction from source code. *In proceedings of the 18th IEEE International Conference on Automated Software Engineering*, 2003, 215–224.
- [24] **Y-G. Gueheneuc, H. Sahraoui, F. Zaidi.** Fingerprinting design patterns. *In proceedings of the 11th Working Conference on Reverse Engineering*, 2004, 172–181.
- [25] **R. Ferenc, A. Beszedes, L. Fulop, J. Lele.** Design pattern mining enhanced by machine learning. *In proceedings of the 21st IEEE International Conference on Software Maintenance*, 2005, 295–304.
- [26] **J. McC. Smith, D. Stotts.** Elemental design patterns: A logical inference system and theorem prover support for flexible discovery of design patterns. *Technical Report TR02-038, Department of Computer Science, University of North Carolina*, 2002.
- [27] **J. Fabry, T. Mens.** Language independent detection of object-oriented design patterns. *Computer Languages, Systems & Structures*, 30(1-2), 2004, 21–33.
- [28] **R. Wille.** Formal Concept Analysis as Mathematical Theory of Concepts and Concept Hierarchies. *Formal Concept Analysis, Springer*, 2005, 1-33.
- [29] **P. Tonella, G. Antoniol.** Object Oriented Design Pattern Inference. *In proceedings of the 5th Symposium on Software Development Environments*, 1999, 230–238.
- [30] Apache Velocity. [interactive][accessed 2010-09-20]. <http://velocity.apache.org/>.
- [31] W3C consortium. XSLT specification. [interactive][accessed 2010-09-20]. <http://www.w3.org/TR/xslt>.
- [32] Eclipse Modeling, Model to Text, Xpand. [interactive][accessed 2010-09-20]. <http://www.eclipse.org/modeling/m2t/?project=xpand>.
- [33] Eclipse Modeling, Model to Text, JET. [interactive][accessed 2010-09-20]. <http://www.eclipse.org/modeling/m2t/?project=jet>.
- [34] **M. Bork, L. Geiger, C. Schneider, A. Zündorf.** Towards Roundtrip Engineering – a Template-Based Reverse Engineering Approach. *In proceedings of the 4th European conference on Model Driven Architecture: Foundations and Applications, LNCS*, 5095, 2008, 33–47.
- [35] OMG group. Unified modeling language: superstructure. [interactive][accessed 2010-09-20]. <http://www.omg.org/cgi-bin/doc?formal/07-02-03>.

Received September 2010.

DOI: 10.5755/j01.itc.39.4.12377