

A NEW WAVELET-BASED APPROACH TO PROGRESSIVE ENCODING OF REGIONS OF INTEREST IN A DIGITAL SIGNAL

Jonas Valantinas, Deividas Kančelkis

*Department of Applied Mathematics, Kaunas University of Technology
Studentų St. 50-325c, LT-51368 Kaunas, Lithuania
e-mail: jonas.valantinas@ktu.lt, deividas.kancelkis@stud.ktu.lt*

Abstract. Progressive digital signal encoding and subsequent transmission refer to signal compression techniques that allow both the original signal reconstruction without loss of any detail and the construction of signal approximations (estimates) with the accuracy level depending on the amount of data available. Locally progressive encoding and transmission can be achieved by first transmitting a “rough” estimate of the original signal, then sending further details related to one or another selected block (region of interest - ROI) of the signal. In this paper, we propose a new wavelet-based approach to implementing of a locally progressive digital signal coding idea. The proposed approach explores both the newly developed fast procedures for evaluation of the discrete wavelet (Haar, LeGall) transform for particular selected ROI in the digital signal and the zero-tree-based encoders with an improved zero-tree analysis scheme.

Keywords: discrete wavelet transform, progressive signal compression, ROI coding.

1. Introduction

Historically, the discrete wavelet transform (DWT) has gained widespread acceptance in fields of signal processing and image compression [1-4]. In the wavelet transform, dilations (scaling) and translations (shifts) of a mother wavelet are used to perform a spatial, as well as a frequency, analysis of the input digital image (signal). Due to the multi-resolution nature of DWT, it has been successively adopted by the new image compression standard JPEG2000 [5].

Wavelet transform is a new technique that is introduced in many signal processing applications. In recent years, wavelet-based compression techniques and tools have received significant attention, especially for different biomedical signal-processing applications [6-9]. It is notorious that wavelet-based coding is more robust under transmission of images (signals) and facilitates their progressive reconstruction [7, 10, 11].

Many kernels can be used for DWT, like those of Daubechies, Morlet, Meyer or the discrete Haar transform (HT) [12]. The latter one is the simplest form of the Wavelet Transform family. Since its popularity in wavelet analysis, there are some definitions and various algorithms for calculating HT [12, 13]. Despite the obvious fact that Haar wavelets always have been chosen for educational purpose, many ideas and algorithms developed and implemented with the use of HT later on were successively generalized to include wavelets of higher orders (Le Gall, Daubechies, etc.).

Due to the fully localized nature of the discrete Haar wavelet transform it is possible to specify any block (region of interest – ROI) of the signal to be compressed. This property of the Haar wavelet transform can also be used in the progressive digital signal transmission schemes, by which only the information corresponding to the localized ROI in the signal will be sent progressively.

It should be observed that more complex wavelet transforms (Le Gall, Daubechies, etc.), due to their partially localized nature, cannot serve the purpose directly. These transforms should undergo preliminary task-oriented modifications, ensuring partial separation of signal blocks in the DWT spectrum of the signal under processing. One such modification, concerning the discrete Le Gall transform (DLGT), is proposed in Section 2.2.

The locally progressive image (signal) coding idea is not a new one. The possibility of defining regions of interest (blocks) in digital images is a significant feature of the latest image compression standard JPEG 2000 [5]. A priori selected image blocks are coded with better quality than the rest of the image. This is done by scaling the wavelet coefficients so that the bits associated with the selected image blocks are placed in higher bit planes and, clearly, transmitted first.

In this paper, the locally progressive digital signal coding idea is cultivated and implemented in a slightly

different way – the regions of interest (ROI) in the input digital signal are selected at the request of the user. The user makes his choice just after he receives a “rough” (recognizable!) estimate of the signal. The proposed digital signal coding idea explores both the zero-tree-based signal encoders with an improved zero-tree analysis scheme and the newly developed exceptionally fast procedures for the determination of discrete wavelet (Haar, Le Gall) spectra for the selected ROI. The latter procedures lean upon the assumption that the discrete wavelet spectrum of the original input signal is known and plays a significant role in ensuring reasonably high overall performance of the approach.

2. Computing the discrete wavelet transform for digital signals

The discrete wavelet transform (DWT) itself represents an iterative procedure. Each iteration (step) of the DWT applies the scaling function to the data input (digital signal). If the original signal X has N ($N = 2^n$, $n \in \mathbb{N}$) values, the scaling function will be applied in the wavelet transform iteration to calculate $N/2$ averaged (smoothed) values. In the ordered wavelet transform the smoothed values are stored in the upper half of the N element input vector.

The wavelet function (in each step of the wavelet transform) is also applied to the input data. If the original signal has N values, the scaling function will be applied to calculate $N/2$ differences (reflecting change in the data). In the ordered wavelet transform, the wavelet (differenced) values are stored in the lower half of the N element input vector.

On the subsequent iteration, both mentioned functions (scaling and wavelet) are applied repeatedly to the ordered set of smoothed values calculated during the preceding iteration.

After a finite number of iterations (n steps) the DWT spectrum Y of the digital signal X is found. The vector Y comprises the only smoothed value (obtained in the n -th iteration) and the ordered set of differenced values (obtained in the $n-1$ preceding iterations).

Below, we present some newly developed fast procedures for evaluation of the discrete wavelet (Haar, Le Gall) spectra for selected (under the user’s request) regions of interest (ROI) in the digital signal. The proposed procedures refer to the assumption that the DWT spectrum of the original input signal is known.

2.1. Fast evaluation of the discrete Haar spectra for the requested ROI

The discrete Haar transform (HT) has two scaling and wavelet function coefficients. The scaling function coefficients are – $h_0 = 1$ and $h_1 = 1$, while the

wavelet function coefficient values are – $g_0 = h_1 = 1$ and $g_1 = -h_0 = -1$.

The scaling and wavelet functions are calculated by taking the scalar product of the coefficients and two data values. Let $X = (x_0 \ x_1 \ x_2 \ \dots \ x_{N-2} \ x_{N-1})^T$ be an original digital signal ($N = 2^n$, $n \in \mathbb{N}$). The discrete Haar spectrum Y of X is obtained in n iterations. Let

$$S^{(i)} = (s_0^{(i)} \ s_1^{(i)} \ s_2^{(i)} \ \dots \ s_{2^{n-i}-1}^{(i)})^T$$

and

$$D^{(i)} = (d_0^{(i)} \ d_1^{(i)} \ d_2^{(i)} \ \dots \ d_{2^{n-i}-1}^{(i)})^T$$

be the result of application of the Haar scaling and wavelet functions to the data vector $S^{(i-1)}$ ($i \in \{1, 2, \dots, n\}$; besides, $S^{(0)} = X$, i.e. $s_k^{(0)} = x_k$, for $k = 0, 1, \dots, N-1$), respectively. Now, the above scalar product can be put down as follows:

$$\begin{aligned} s_k^{(i)} &= h_0 \cdot s_{2k}^{(i-1)} + h_1 \cdot s_{2k+1}^{(i-1)} = s_{2k}^{(i-1)} + s_{2k+1}^{(i-1)}, \\ d_k^{(i)} &= g_0 \cdot s_{2k}^{(i-1)} + g_1 \cdot s_{2k+1}^{(i-1)} = s_{2k}^{(i-1)} - s_{2k+1}^{(i-1)}, \end{aligned}$$

for all $k = 0, 1, \dots, 2^{n-i} - 1$. Thus, the discrete Haar spectrum Y of the digital signal X takes the form:

$$Y = (s_0^{(n)} \ d_0^{(n)} \ d_0^{(n-1)} \ d_1^{(n-1)} \ d_0^{(n-2)} \ d_1^{(n-2)} \ d_2^{(n-2)} \ d_3^{(n-2)} \ \dots \ \dots \ d_0^{(1)} \ d_1^{(1)} \ \dots \ d_{N/2-1}^{(1)})^T.$$

The inverse HT is defined by the following equalities:

$$s_{2k}^{(i-1)} = \frac{1}{2}(s_k^{(i)} + d_k^{(i)}), \quad s_{2k+1}^{(i-1)} = \frac{1}{2}(s_k^{(i)} - d_k^{(i)}),$$

where $k = 0, 1, \dots, 2^{n-i} - 1$ and $i \in \{1, 2, \dots, n\}$. It will be observed that the energy normalization factors across the different scales (in the above expressions) are missing.

Each spectral coefficient $d_j^{(i)}$ ($i = 1, 2, \dots, n$; $j = 0, 1, \dots, 2^{n-i} - 1$) possesses a very interesting and valuable property – it is associated with a unique signal block $X_j^{(i)} = (x_{2^i \cdot j} \ x_{2^i \cdot j+1} \ \dots \ x_{2^i(j+1)-1})^T$, i.e. numerical value of the coefficient $d_j^{(i)}$ is defined exceptionally by $X_j^{(i)}$ (Haar wavelets are very well localized in space!).

A simple analysis of algebraic operations used in the definition of the HT spectrum (above expressions) made it possible to develop and implement a new exceptionally fast procedure for the determination of numerical values of Haar spectral coefficients for the selected ROI in the digital signal.

Let us denote the discrete HT spectrum of the region of interest (block) $X_j^{(i)}$ ($i \in \{1, 2, \dots, n\}$, $j \in \{0, 1, \dots, 2^{n-i} - 1\}$) by $Y_j^{(i)}$. Obviously, $Y_0^{(n)} = Y$ and $X_0^{(n)} = X$. Then:

(1) The very first spectral coefficient (smoothed value $s_j^{(i)}$) in $Y_j^{(i)}$ is specified by:

$$s_j^{(i)} = \frac{1}{2^{n-i}} \left(s_0^{(n)} + \sum_{r=1}^{n-i} (-1)^{j-r} \cdot 2^{n-i-r} \cdot d_{j_r}^{(i+r)} \right),$$

where: $j_0 = j$, $j_r = \lfloor j_{r-1}/2 \rfloor$, for all $r = 1, 2, \dots, n-i$, and $\lfloor x \rfloor$ stands for the integral part of the real number x ;

(2) The rest spectral coefficients (differenced values) in $Y_j^{(i)}$ are extracted from the discrete HT spectrum Y of X , i.e. they are identified with the ordered set of differenced (wavelet) coefficients

$$\{d_j^{(i)}, d_{2j}^{(i-1)}, d_{2j+1}^{(i-1)}, d_{4j}^{(i-2)}, d_{4j+1}^{(i-2)}, d_{4j+2}^{(i-2)}, d_{4j+3}^{(i-2)}, \\ d_{8j}^{(i-3)}, \dots, d_{8j+7}^{(i-3)}, \dots, d_{2^{i-1}j}^{(1)}, d_{2^{i-1}j+1}^{(1)}, \dots, d_{2^{i-1}(j+1)-1}^{(1)}\};$$

the latter set is often called a tree with the root $d_j^{(i)}$.

Thus, the discrete Haar spectrum $Y_j^{(i)}$ of the ROI $X_j^{(i)}$ is given by:

$$Y_j^{(i)} = (s_j^{(i)} d_j^{(i)} d_{2j}^{(i-1)} d_{2j+1}^{(i-1)} d_{4j}^{(i-2)} d_{4j+1}^{(i-2)} d_{4j+2}^{(i-2)} d_{4j+3}^{(i-2)} \\ d_{8j}^{(i-3)} \dots d_{2^{i-1}j}^{(1)} d_{2^{i-1}j+1}^{(1)} \dots d_{2^{i-1}(j+1)-1}^{(1)})^T.$$

Consistent patterns of the above relationships, as well as knowledge of the detailed scheme for the direct evaluation of HT spectra for digital signals (Fast Haar Transform, [13]), made it possible to compare both approaches (direct evaluation, proposed procedure) and estimate time expenditures associated with them (Table 1). Comparative analysis was done for the ROI of size 2^i ($6 \leq i \leq n-1$; $N = 2^n = 4096$ being the size of the input signal X).

Table 1. Comparison of two approaches to finding HT spectra for ROI of size 2^i

N	i	6	7	8	9	10	11
1024		2.28	5.43	5.25	5.56	-	-
2048		2.00	3.41	4.81	4.94	5.76	-
4096		1.94	2.74	3.33	5.22	5.67	5.50

The achievable speed gain is expressed in terms of ρ ($\rho = \tau_d / \tau_{pr}$), where τ_d specifies the time needed for direct evaluation of HT spectra for indicated ROI and τ_{pr} – that needed by the proposed procedure.

2.2. Fast evaluation of the discrete Le Gall spectra for the requested ROI

The discrete Le Gall transform (DLGT) has five scaling and three wavelet function coefficients. The scaling function coefficients are – $h_0 = -1/8$, $h_1 = 1/4$, $h_2 = 3/4$, $h_4 = 1/4$ and $h_5 = -1/8$, whereas

the wavelet function coefficient values are – $g_0 = -1/2$, $g_1 = 1$ and $g_2 = -1/2$. The scaling and wavelet functions are calculated by taking the scalar product of the coefficients and five or three data values. In practice, to compute the DLGT spectrum Y of the digital input signal X of size $N = 2^n$ ($n \in \mathbb{N}$), an efficient procedure (Lifting Scheme, [3, 4]) is applied, namely (the same notations, as in Section 2.1, are used):

$$d_k^{(i)} = s_{2k+1}^{(i-1)} - \frac{1}{2} (s_{2k}^{(i-1)} + s_{2k+2}^{(i-1)}),$$

$$s_k^{(i)} = s_{2k}^{(i-1)} + \frac{1}{4} (d_{k-1}^{(i)} + d_k^{(i)}),$$

for all $k = 0, 1, \dots, 2^{n-i} - 1$; here $s_{2^{n-i+1}}^{(i-1)} := o_{2^{n-i+1}-1}^{(i-1)}$, $d_{-1}^{(i)} := d_0^{(i)}$ and $i \in \{1, 2, \dots, n\}$.

The inverse DLGT is specified by:

$$s_{2k}^{(i-1)} = s_k^{(i)} - \frac{1}{4} (d_{k-1}^{(i)} + d_k^{(i)}),$$

$$s_{2k+1}^{(i-1)} = d_k^{(i)} + \frac{1}{2} (s_{2k}^{(i-1)} + s_{2k+2}^{(i-1)}),$$

for all $k = 0, 1, \dots, 2^{n-i} - 1$ and $i \in \{1, 2, \dots, n\}$.

The “edge” problem which takes place at both ends of the data vector (on each iteration) and which determines the partially localized nature of the discrete Le Gall transform, here (Lifting Scheme) is solved by treating the data vector as if it was mirrored at the ends.

If we transfer the said “edge” problem to non-overlapping ROI of size 2^m ($m \in \{1, 2, \dots, n-1\}$), comprising the input signal X , we would be able to “decorrelate” (in the DLGT spectrum of X) ROI of size not less than 2^m , i.e. we would be able to associate those regions of interest with particular wavelet coefficients in Y .

Following this perception, we have developed a slightly modified lifting scheme, namely:

$$d_k^{(i)} = \begin{cases} s_{2k+1}^{(i-1)} - s_{2k}^{(i-1)}, & k \in \{l_i - 1, 2l_i - 1, \dots, q_i l_i - 1\}, \\ s_{2k+1}^{(i-1)} - \frac{1}{2} (s_{2k}^{(i-1)} + s_{2k+2}^{(i-1)}), & \text{otherwise,} \end{cases}$$

$$s_k^{(i)} = \begin{cases} s_{2k}^{(i-1)} + \frac{1}{2} d_k^{(i)}, & k \in \{0, l_i, 2l_i, \dots, (q_i - 1)l_i\}, \\ s_{2k}^{(i-1)} + \frac{1}{4} (d_{k-1}^{(i)} + d_k^{(i)}), & \text{otherwise,} \end{cases}$$

for all $k = 0, 1, \dots, 2^{n-i} - 1$ and $i \in \{1, 2, \dots, n\}$; here: $l_i = 2^{m-i}$, $q_i = 2^{n-m}$, for $i = 1, 2, \dots, m$, and $l_i = 1$, $q_i = 2^{n-i}$, for $i = m+1, m+2, \dots, n$. Evidently, $l_i q_i$ equals the size of $S^{(i)}$, $i = 1, 2, \dots, n$.

The modified lifting scheme for the inverse DLGT has also been developed, and is presented below:

$$s_{2k}^{(i-1)} = \begin{cases} s_k^{(i)} - \frac{1}{2}d_k^{(i)}, & k \in \{0, l_i, 2l_i, \dots, (q_i - 1)l_i\}, \\ s_k^{(i)} - \frac{1}{4}(d_{k-1}^{(i)} + d_k^{(i)}), & \text{otherwise,} \end{cases}$$

$$s_{2k+1}^{(i-1)} = \begin{cases} d_k^{(i)} + s_{2k}^{(i-1)}, & k \in \{l_i - 1, 2l_i - 1, \dots, q_i l_i - 1\}, \\ d_k^{(i)} + \frac{1}{2}(s_{2k}^{(i-1)} + s_{2k+2}^{(i-1)}), & \text{otherwise,} \end{cases}$$

for all $k = 0, 1, \dots, 2^{n-i} - 1$ and $i \in \{1, 2, \dots, n\}$.

To map integers to integers (lossless encoding), the above expressions should undergo minor changes similar to those presented in the original version of the lifting scheme [3, 4].

Now, as in the case of the discrete Haar transform (Section 2.1), any Le Gall spectral coefficient $d_j^{(i)}$ ($i \in \{m, m+1, \dots, n\}$, $j \in \{0, 1, \dots, 2^{n-i} - 1\}$) is put into one-to-one correspondence with the signal block (region of interest) $X_j^{(i)} = (x_{2^i \cdot j} \ x_{2^i \cdot j+1} \ \dots \ x_{2^i(j+1)-1})^T$, i.e. numerical value of $d_j^{(i)}$ is defined exceptionally by $X_j^{(i)}$ (Le Gall wavelets become very well localized in space!).

To find the DLGT spectrum $Y_j^{(i)}$ of $X_j^{(i)}$, where $i \in \{m, m+1, \dots, n\}$ and $j \in \{0, 1, \dots, 2^{n-i} - 1\}$, the following newly developed fast procedure should be applied:

(1) The very first spectral coefficient (smoothed value $s_j^{(i)}$) in $Y_j^{(i)}$ is specified by:

$$s_j^{(i)} = s_0^{(n)} - \frac{1}{2} \sum_{r=1}^{n-i} (-1)^{j_r} \cdot d_{j_r}^{(i+r)};$$

here: $j_0 = j$, $j_r = \lfloor j_{r-1}/2 \rfloor$, for all $r = 1, 2, \dots, n-i$;

(2) The rest spectral coefficients (differenced values) in $Y_j^{(i)}$ are extracted from the discrete DLGT spectrum Y of X , i.e. they are identified (as in the case of HT; Section 2.1) with the ordered set of wavelet coefficients

$$\{d_j^{(i)}, d_{2j}^{(i-1)}, d_{2j+1}^{(i-1)}, d_{4j}^{(i-2)}, d_{4j+1}^{(i-2)}, d_{4j+2}^{(i-2)}, d_{4j+3}^{(i-2)}, \\ d_{8j}^{(i-3)}, \dots, d_{8j+7}^{(i-3)}, \dots, d_{2^{i-1} \cdot j}^{(1)}, d_{2^{i-1} \cdot j+1}^{(1)}, \dots, d_{2^{i-1}(j+1)-1}^{(1)}\}.$$

Thus, the discrete Le Gall spectrum $Y_j^{(i)}$ for the signal block (region of interest) $X_j^{(i)}$ of size not less than 2^m ($m \in \{1, 2, \dots, n-1\}$) is given by:

$$Y_j^{(i)} = (s_j^{(i)} \ d_j^{(i)} \ d_{2j}^{(i-1)} \ d_{2j+1}^{(i-1)} \ d_{4j}^{(i-2)} \ d_{4j+1}^{(i-2)} \ d_{4j+2}^{(i-2)} \ d_{4j+3}^{(i-2)} \\ d_{8j}^{(i-3)} \ \dots \ d_{2^{i-1} \cdot j}^{(1)} \ d_{2^{i-1} \cdot j+1}^{(1)} \ \dots \ d_{2^{i-1}(j+1)-1}^{(1)})^T.$$

In Table 2, some experimental analysis results on the efficiency of the proposed procedure, in comparison with the direct evaluation (Lifting Scheme, [4]) of DLGT for the selected ROI in the signal, are

presented. The achievable speed gain (as before; Section 2.1) is expressed in terms of ρ ($\rho = \tau_d / \tau_{pr}$).

Table 2. Comparison of two approaches to finding DLGT spectra for ROI of size 2^i

N	i	6	7	8	9	10	11
1024		25.8	51.7	87.1	122	-	-
2048		22.1	55.5	76.3	127	160	-
4096		25.8	44.3	76.3	122	172	238

3. A new approach to locally progressive encoding of digital signals

The proposed locally progressive digital signal coding and transmitting idea explores both fast evaluation of the discrete wavelet (Haar, Le Gall) transform for the requested ROI in the digital signal (Section 2) and wavelet-based digital signal encoders (EZW, SPIHT, etc.) with an improved zero-tree analysis scheme (Section 3.1). The embedded zero-tree wavelet (EZW) algorithm, as well as the set partitioning in hierarchical trees (SPIHT) procedure, is one of the most efficient coding schemes, which are developed for wavelets [10, 11].

The EZW algorithm transmits the large (significant) wavelet coefficients before transmitting the smaller coefficients. This is done by realizing multiple passes over the discrete wavelet spectrum of the image, lowering the threshold T by a factor of two each time [10].

Namely these multiple passes over the wavelet coefficients, in search of zero-trees, make the EZW encoder heavily time dependent.

Below, we present a novel improved zero-tree analysis scheme, which stops short at a single scanning of the DWT spectrum of the signal under processing and improves the overall performance of the EZW encoder.

3.1. An improved zero-tree analysis scheme in the EZW algorithm

Let $X = (x_0 \ x_1 \ x_2 \ x_3 \ x_4 \ x_5 \ \dots \ x_{N-2} \ x_{N-1})^T$ be a given digital signal of size $N = 2^n$ ($n \in \mathbb{N}$) and

$$Y = (s_0^{(n)} \ d_0^{(n)} \ d_0^{(n-1)} \ d_1^{(n-1)} \ d_0^{(n-2)} \ \dots \ d_{2^{n-1}-1}^{(1)})^T$$

be its DWT spectrum. Let $r_{\max} = \max_{i,j} \{ \lfloor \log_2 |d_j^{(i)}| \rfloor \}$.

Consider the wavelet coefficient $d_j^{(i)}$ ($i \in \{1, 2, \dots, n\}$, $j \in \{0, 1, \dots, 2^{n-i} - 1\}$) which is the root (parent) of the tree

$$\{d_j^{(i)}, d_{2j}^{(i-1)}, d_{2j+1}^{(i-1)}, d_{4j}^{(i-2)}, d_{4j+1}^{(i-2)}, \dots, d_{2^{i-1}(j+1)-1}^{(1)}\}$$

Let us associate $d_j^{(i)}$ with two binary codes (one for the offspring of $d_j^{(i)}$, another for the descendants of $d_j^{(i)}$, except offspring), namely:

$$\text{CodeOff}(i, j) = \langle u_{r_{\max}}(i, j) \dots u_1(i, j) u_0(i, j) \rangle,$$

$$\text{CodeDes}(i, j) = \langle v_{r_{\max}}(i, j) \dots v_1(i, j) v_0(i, j) \rangle.$$

The above codes are generated by a single scanning of the DWT spectrum Y , namely:

(1) $u_t(i, j) = 1$, if $|d_{2j}^{(i-1)}|$ and/or $|d_{2j+1}^{(i-1)}|$ fall into the half-open interval $[2^t, 2^{t+1})$, $t \in \{0, 1, \dots, r_{\max}\}$, and $u_t(i, j) = 0$, otherwise;

(2) $v_t(i, j) = u_t(i-1, 2j) \vee u_t(i-1, 2j+1)$, for $i = 3$, and

$$v_t(i, j) = u_t(i-1, 2j) \vee u_t(i-1, 2j+1) \vee v_t(i-1, 2j) \vee v_t(i-1, 2j+1),$$

for $i = 4, 5, \dots, n$.

It should be emphasized that generation of binary codes $\text{CodeOff}(i, j)$, for all possible values of i and j , requires $(N-2)$ verifications of falling into one or another half-open interval, while that for $\text{CodeDes}(i, j)$ requires $(3N/4-4)$ logical additions on binary codes of length $r_{\max}+1$.

Thus, to state that a particular wavelet coefficient $d_j^{(i)}$ ($i \in \{1, 2, \dots, n\}$, $j \in \{0, 1, \dots, 2^{n-i}-1\}$) is the root of a particular zero-tree with respect to the threshold $T = T_r = 2^r$, $r \in \{0, 1, \dots, r_{\max}\}$, it suffices to ascertain that $u_r(i, j) = 0$ and $v_r(i, j) = 0$.

Preliminary experimental results show that implementation of the improved zero-tree analysis scheme increases the overall performance of the EZW encoder nearly (10-15) %.

The described zero-tree analysis scheme can be successively applied also to the SPIHT algorithm, in processing lists of insignificant pixels and those of insignificant sets [11].

3.2. Experimental results and their analysis

To motivate the proposed locally progressive digital signal coding idea, an illustrative experiment has been carried out – the developed procedure has been applied to processing of the electrocardiogram (ECG) data. Computer simulation was performed on a PC with CPU PENTIUM4 2.8 GHz, RAM 2 GB, OS Windows XP; Programming language Java.

To simplify a description of the obtained results, we here introduce the following notations: the CPU time required to perform the discrete Le Gall transform (DLGT) of the digital signal (or that of ROI) is denoted by τ_1 , to perform wavelet-based (EZW) encoding of the signal (or that of ROI) – by τ_2 , to transmit data across a low communications channel – by τ_3 .

Three cases were analyzed and compared: first of all, a non-compressed signal (ECG) was sent across the low communications channel to the user (Fig. 1, a); secondly, lossless encoding (EZW) in the Le Gall spectral domain was applied to the ECG, and compressed signal was sent to the user (Fig. 1, b); thirdly, the ECG signal was processed (lossy encoding by the EZW algorithm), a “rough” estimate of ECG was sent to the user, the selected (at the user’s request) region of interest in the signal was processed by applying both the DLGT and the EZW encoder, and then a high quality estimate of the selected ROI was sent again to the user (Figure 1, c).

We have also assumed that the bandwidth of the communications channel equaled 19.2 Kbps.

Obviously, transmitting of non-processed data X (ECG; Figure 2, a) across the channel (Figure 1, a) requires $\tau = \tau_3 = 1.67$ s.

Computing the DLGT spectrum of the ECG signal X , wavelet-based processing (EZW, lossless encoding) and sending across the channel (Figure 1, b) requires (in total) $\tau = \tau_1 + \tau_2 + \tau_3 = 0.021 + 0.036 + 0.287 = 0.344$ s. Worth emphasizing, lossless encoding of the ECG reduces the data amount from 4096 B to 658 B, i.e. the signal compression effect ($\beta = 6.22$) is achieved.

The developed approach (Figure 1, c), when applied to the ECG signal, requires: as before, $\tau_1 = 0.021$ s, for computing the DLGT spectrum of the original signal (ECG) X ; $\tau_2 = 0.02$ s, for EZW encoding of X ($T = T_3 = 8$; 93 B of compressed data Z); $\tau_3 = 0.055$ s, for transmitting of Z to the user and restoring the “rough” estimate \tilde{X} of the original signal X (Figure 2, b); $\tau_1 = 0.001$ s, for computing the DLGT of the selected ROI $X_2^{(9)}$; $\tau_2 = 0.002$ s, for EZW encoding of $X_2^{(9)}$ ($T = T_1 = 1$; 81 B of compressed data $Z_2^{(9)}$); $\tau_3 = 0.035$ s, for transmitting and restoring of the high quality estimate $\tilde{X}_2^{(9)}$ of the selected signal block (Figure 2, c). So, the total time expenditure equals $\tau = \tau_1 + \tau_2 + \tau_3 + \tau_1 + \tau_2 + \tau_3 = 0.134$ s. The speed gain is noticeable, in comparison with cases 1 and 2.

In Figure 2 (d), some additional ROI of the ECG signal X , namely, $X_0^{(10)}$ and $X_1^{(11)}$ are processed and analyzed. Compression details of the selected ROI, as well as peak signal-to-noise ratio values are also indicated.

Since in each case the user has the necessary ROI (Figure 2, a, c, d) available, we come to the conclusion that the proposed locally progressive digital signal coding idea may lead (especially, when applied to multi-dimensional signals, characterized by large amounts of data) to auspicious and fast-track results.

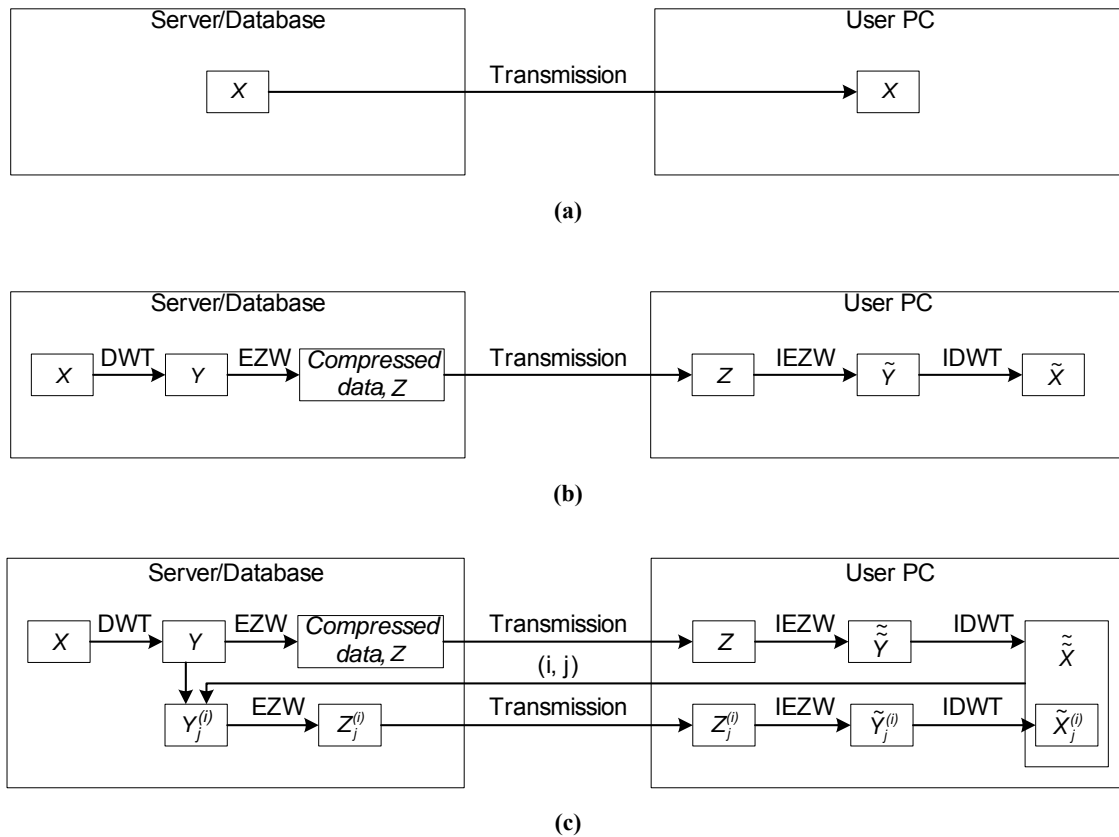

Figure 1. The electrocardiogram (ECG) data processing and transmission: (a) the ECG signal is sent across the low communications channel to the user; (b) lossless encoding (EZW) is applied to the signal, whereupon compressed signal is sent to the user; (c) the proposed locally progressive digital signal encoding and transmitting approach

4. Conclusion

In the paper, original fast procedures for the determination of the discrete wavelet (Haar, Le Gall) spectra for the selected regions of interest (ROI) in the digital signal are presented. The procedures explore specific properties of discrete wavelet transforms (DWT) and refer to the assumption that DWT spectrum of the original digital signal is known. It is shown that the developed procedures can be successfully applied to implementing of a locally progressive digital signal coding idea (approach). The essence of the approach – additional bit streams are used to add new details not to the whole signal under processing but to the selected (at the request of the user) ROI in the signal. The overall performance of the approach is improved by implementing efficient wavelet-based signal encoders (EZW, SPIHT, etc.) with a novel enhanced zero-tree analysis scheme.

Comparison of the developed locally progressive digital signal coding technique with other approaches is complicated because the latter approaches analyze and process (mostly) a priori chosen ROI.

We unreservedly believe that the developed approach will find various applications in implementing efficient and up-to-date digital data processing technologies. In particular, the proposed idea can be explored when large amounts of requested graphical data are being sent across a slow communications channel (say, the Internet).

In the nearest future, a similar analysis, concerning higher order wavelet transforms (Daubechies D4, Daubechies 9/7, etc.), is supposed. In parallels, a generalization of the locally progressive coding idea, to include two-dimensional digital signals (images), is planned too.

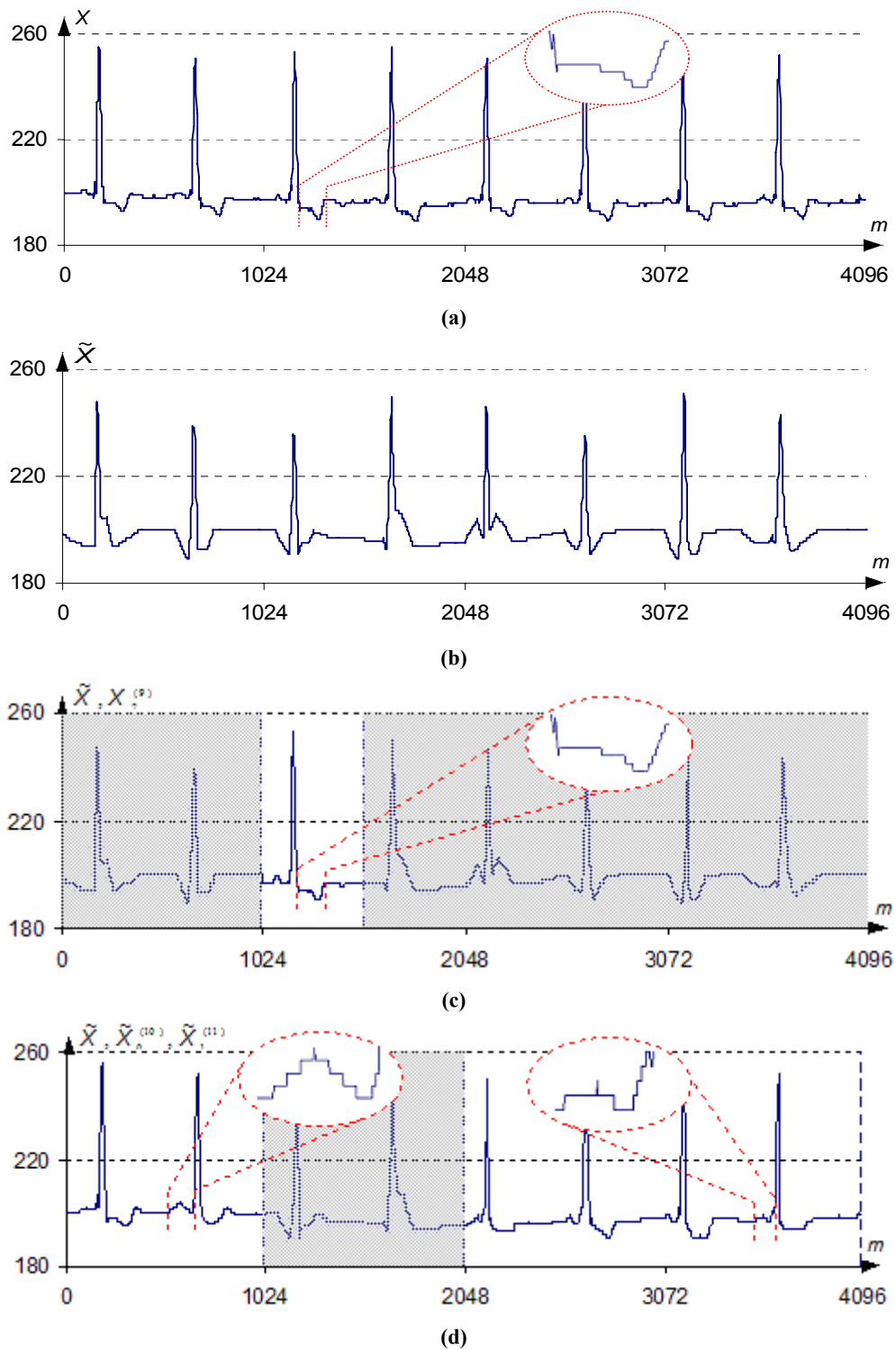

Figure 2. The ECG data processing: (a) the original signal X ($N = 2^{12} = 4096$); (b) the “rough” estimate \tilde{X} of X ($T = T_3 = 8$, $\beta = 44.03$, PSNR = 34.81); (c) the selected region of interest $X_2^{(9)}$ ($T = T_0 = 1$, $\beta = 6.32$); (d) high quality estimates of $X_0^{(10)}$ ($T = T_1 = 2$, $\beta = 14.84$, PSNR = 40.78) and $\tilde{X}_1^{(11)}$ ($T = T_1 = 2$, $\beta = 14.84$, PSNR = 44.35)

References

- [1] **I. Daubechies.** Ten Lectures on Wavelets. *SIAM, Philadelphia*, 1992.
- [2] **Y.T. Chan.** Wavelet Basics. *Kluwer Academic Publishers, Norwell, MA*, 1995.
- [3] **M. Vetterli.** Wavelets, approximation and compression. *IEEE Signal Processing Mag.*, Vol.18, No.5, 2001, 59-73.
- [4] **A. Jense, A. la Cour-Harbo.** *Ripples in Mathematics: the Discrete Wavelet Transform.* Springer, 2001.
- [5] **C. Christopoulos, A. Skodras, T. Ebrahimi.** The JPEG2000 Still Image Coding System, An Overview. *IEEE Trans. on Consumer Electronics*, Vol.46, No.4, 2000, 1103-1127.
- [6] **R.S.H. Istepanian, A.A. Petrosian.** Optimal Zonal Wavelet-Based ECG Data Compression for Mobile Telecardiology System. *IEEE Trans. Inform. Technol. Biomed.*, Vol.4, 2000, 200-211.
- [7] **M.L. Hilton.** Wavelet and Wavelet Packet Compression of Electrocardiograms. *IEEE Trans. Biomed. Eng.*, Vol.44, 1997, 394-402.
- [8] **Z. Lu, D.Y. Kim, W.A. Pearlman.** Wavelet Compression of ECG Signals by the Set Partitioning in Hierarchical Trees Algorithm. *IEEE Trans. Biomed. Eng.*, Vol.47, 2000, 849-856.
- [9] **R.S.H. Istepanian, L.J. Hadjileontiadis, S.M. Pannas.** ECG Data Compression Using Wavelets and Higher Order Statistics Methods. *IEEE Trans. Inform. Technol. Biomed.*, Vol.5, 2001, 108-115.
- [10] **J.M. Shapiro.** Embedded image coding using zero-trees of wavelet coefficients. *IEEE Trans. Signal Processing*, Vol.41, 1993, 3445-3462.
- [11] **A. Said, W.A. Pearlman.** A new, fast, and efficient image codec based on set partitioning in hierarchical trees. *IEEE Trans. Circuits Syst. Video Technology*, Vol.6, 1996, 243-250.
- [12] **R.M. Rao, A.S. Bopadikar.** Wavelet Transforms: Introduction to Theory and Applications. *Pearson Education, Asia*, 2002.
- [13] **C. Phang, P. Phang.** Modified Fast and Exact Algorithm for Fast Haar Transform. *International Journal of Computer Science and Engineering*, Vol.2, No.2, 2008, 55-58.

Received April 2009.

DOI: 10.5755/j01.itc.38.3.12127