

ADAPTIVE pH CONTROL SYSTEM FOR FED-BATCH BIOCHEMICAL PROCESSES

Vytautas Galvanauskas

*Process Control Department, Kaunas University of Technology
Studentų St. 50–162, LT–51386 Kaunas, Lithuania
e-mail: Vytautas.Galvanauskas@ktu.lt*

Abstract. In the paper pH control problems in fed-batch biochemical processes are analyzed. Process mathematical model was based on the first principles and identified using available experimental data. An adaptive pH control system based on gain scheduling approach was proposed. Significant increase in control quality as compared to a standard PI control system was achieved.

Keywords: pH control, adaptive control, gain scheduling, fed-batch process.

1. Introduction

Modern biochemical processes are very complex and difficult to control [7]. The dynamics of such processes is nonlinear and time-varying. The problem is even more difficult since there are few reliable online measurement methods for such important biochemical quantities like biomass concentration [7]. Therefore, often application of complex and time consuming mathematical models for off-line optimization, indirect state estimation and optimal online control is required. On the other hand, control systems should use mathematical models as simple as possible in order to avoid high computational load and numerical problems. This makes the task of high quality control complicated.

High quality control of pH is difficult because of many reasons. Some of them are: very strong nonlinearity of biochemical processes, titration curves and pH measurement itself, high sensitivity of the microorganisms even to small temporary deviations of pH level in the cultivation media, and drift of the pH sensors [1, 5].

In the literature there are many approaches for high quality pH control. Nevertheless, most of them suffer from the drawbacks already described [2, 8]. On the other hand, well functioning pH control systems can be used to monitor biological reaction rates [6]. Therefore, it is of primary importance to elaborate simple, robust and easy to implement methods for pH control in fed-batch biochemical processes.

2. Experimental setup

The investigated fed-batch biochemical process was carried out in a laboratory scale bioreactor (B. Braun Biostat ED10). The experimental set-up is presented in Figure 1. The vessel is equipped with pressure and temperature sensors, and probes for pH, and dissolved oxygen concentration measurements. Airflow is measured and controlled by a mass flow controller. The flows of acid, alkali and feeding solutions were controlled using peristaltic pumps. Composition of the exhaust gas was determined by a paramagnetic oxygen analyzer OXOR 610 and an infrared carbon dioxide analyzer UNOR 610.

Signals from the DCU control unit at the bioreactor are transferred to a workstation running B. Braun MFCS software using a RS232C serial communication.

During the cultivations, the medium temperature, the pH, the dissolved oxygen partial pressure, and the head-space over-pressure were controlled via B. Braun DCU front-end control system.

During fed-batch cultivation process performed off-line samples for biomass concentration measurement were taken each 0.5–1 [h]. The biomass concentration was determined using standard dry weight technique [7].

3. Mathematical model of the process

The main controlled variable in the analyzed control system is pH level of the medium which is related to the concentration of free hydrogen ions as follows [1]:

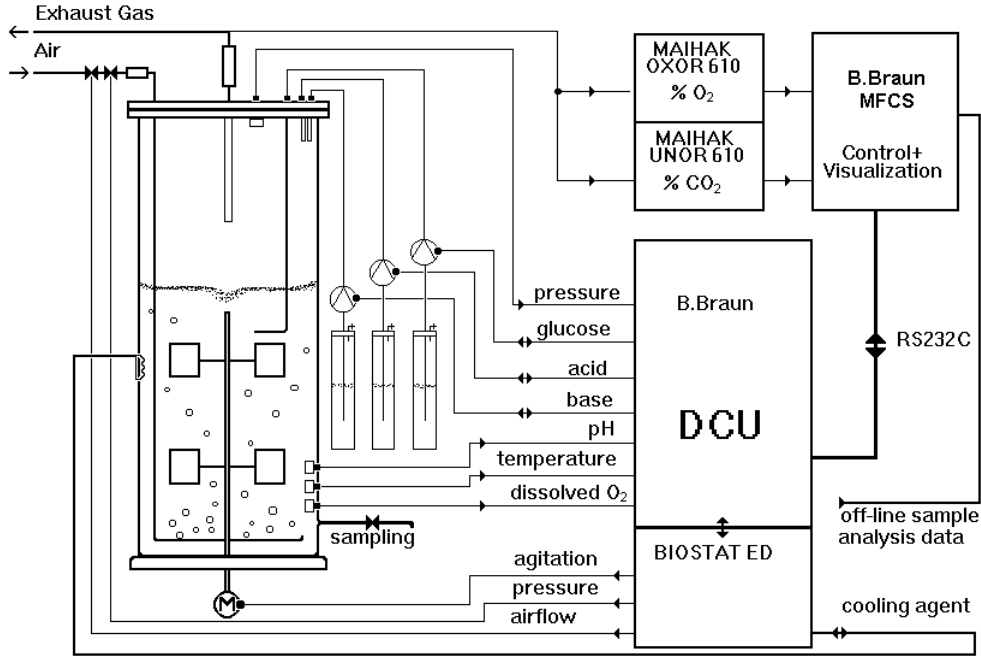

Figure 1. Experimental setup

$$pH = -\log_{10}(C_{H^+}). \quad (1)$$

Concentration of hydrogen-ions in a fed-batch cultivation process can be modelled taking into account influence of bacterial growth, addition of acid and alkali solutions during pH control and dilution effects:

$$\frac{dC_{H^+}}{dt} = (\alpha_1\mu x + \alpha_2x) + \frac{F_{pH}(C_{H^+}^0 - C_{H^+})}{V} - \frac{F_s C_{H^+}}{V}, \quad (2)$$

where:

C_{H^+} and $C_{H^+}^0$ – concentration of hydrogen-ions in the cultivation medium and in the feeding solution, respectively, [mol/l], the latter concentration can differ from the one calculated theoretically and is subjected to model based identification;

x – biomass concentration in the cultivation medium, [g/l];

μ – specific biomass growth rate, [1/h];

F_{pH} – flow of the alkali solution for pH control, [l/h];

F_s – flow of the feeding solution, [l/h];

V – cultivation medium volume, [l];

α_1, α_2 – model parameters to be identified from experimental data.

The terms of the first summand in parenthesis on the right hand side of the differential equation (2) are related to biomass growth and maintenance, respectively. During the metabolic reactions in the microbial culture excessive production of H^+ ions takes place, and the addition of alkali solution is necessary in order to maintain constant pH level which is optimal for the growth of bacteria and/or production of the target product.

The second summand takes into account the influence of the flow of the alkali solution for pH control. The last one accounts for the dilution effect of the feeding solution.

The initial value $C_{H^+}(0)$ is equal to 10^{-7} [mol/l], and this level corresponds to pH 7.

The biomass growth in the fed-batch process can be modelled by means of the differential equation

$$\frac{dx}{dt} = \mu x - \frac{F_s + F_{pH}}{V} x. \quad (3)$$

The initial value $x(0)$ is determined after inoculation, and is known at the beginning of each cultivation process.

Another key quantity of the adaptive control system is oxygen transfer rate, OTR [1]:

$$OTR = \frac{QM_{O_2}}{N_A} \left(C_{O_2in} - C_{O_2out} \frac{100 - C_{O_2in} - C_{CO_2in}}{100 - C_{O_2out} - C_{CO_2out}} \right), \quad (4)$$

where:

OTR – oxygen transfer rate, [g/h];

Q – aeration rate, [NI/h];

M_{O_2} – molar mass of the oxygen, [g/mol];

N_A – Avogadro's number, [mol/l];

C_{O_2in}, C_{CO_2in} – volumetric concentrations of oxygen and carbon dioxide in the aeration flow, respectively, [%];

C_{O_2out}, C_{CO_2out} – volumetric concentrations of oxygen and carbon dioxide in the exhaust gas, respectively, [%].

On the other hand, the oxygen uptake rate, OUR , can be evaluated from the equation taking into account

oxygen demand for the biomass growth and maintenance:

$$OUR = \beta_1 \mu x V + \beta_2 x V, \quad (5)$$

where β_1, β_2 – model parameters to be identified from experimental data.

Cultivation process consists of two distinct phases (biomass growth and product formation phase), in which these coefficients have different values that should be identified separately.

Assuming that oxygen consumption and transfer in the process reaches equilibrium, i. e. $OUR = OTR$, and taking into account (4)-(5) one can calculate the specific biomass growth rate as follows:

$$\mu = \frac{QM_{O_2}}{N_A} \left(C_{O_2in} - C_{O_2out} \frac{100 - C_{O_2in} - C_{CO_2in}}{100 - C_{O_2out} - C_{CO_2out}} \right) \times \frac{1}{\beta_1 x V} - \frac{\beta_2}{\beta_1} \quad (6)$$

All the variables except of x can be measured online during the process. Each time moment the biomass concentration x is obtained applying numerical integration of (3) in real time. The value of μ calculated using (6) is applied in the next integration step solving (3).

Additionally, for the simulation purposes the models for evaluation of feeding and alkali solution flows are elaborated:

$$F_s = \frac{\mu x V}{Y_{xs} S_0}, \quad (7)$$

$$F_{pH} = Y_{ax} \mu x V, \quad (8)$$

where:

S_0 – substrate concentration in the feed, [g/l];

Y_{xs} – biomass/substrate yield coefficient, [g/g];

Y_{ax} – alkali/biomass yield coefficient, [g/g].

4. Identification of the process model parameters

The overall process model consists of the equations (1)-(8). The identification of the process model parameters was performed in several distinctive steps. First, by solving (3)-(8) the unknown parameters β_1 and β_2 were found. These parameters were identified for biomass growth (0–9 [h]) and product formation phase (9–16 [h]) separately. The optimization criterion for the identification procedure was minimal RMS deviation [4] between the modelling results and the experimentally obtained data for x . The model based identification was performed using Matlab/Simulink (Mathworks, Inc.) environment. During the optimization procedure the Nelder-Mead algorithm was used. The identified values of the parameters β_1 and β_2 are given in Table 1.

The modelling trajectories of OUR and x showed good coincidence with the experimental results (see Figure 2). The identification of parameters β_1 and β_2 resulted in 0.45 [g/l] RMS deviation for x .

Table 1

Model parameter	Value		Units
	Phase 1	Phase 2	
β_1	0.8646	1.4700	[g/g]
β_2	0.0180	0.0038	[g/(gh)]

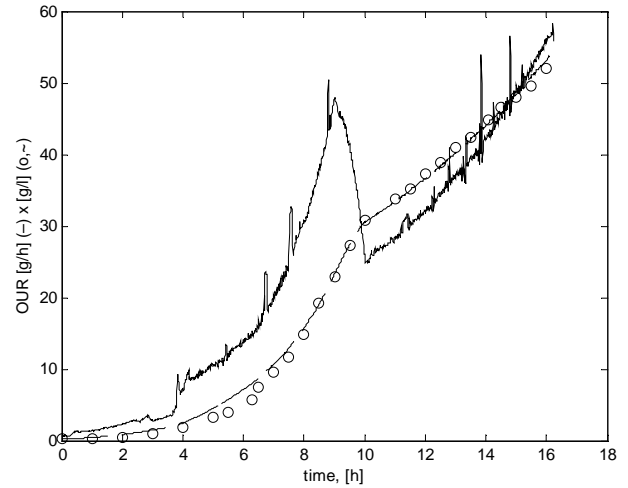

Figure 2. Simulation results of the identified x and OUR model (solid line – OUR ; dashed line – modelled trajectory of x , \circ – experimental data of x)

In the next step of identification procedure, the parameters α_1, α_2 and $C_{H^+}^0$ were identified. For the identification of these parameters, the series of specially designed experiments were used.

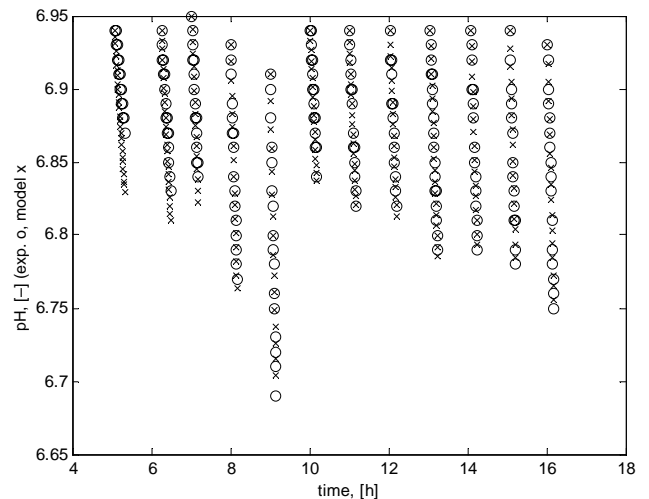

Figure 3. Simulation results of the identified pH model (\circ – experimental data; \times – simulation results)

During the experiments, the pH of media was controlled during the predefined time, later the controller was switched off ($F_{pH} = 0$) letting the pH value to

decrease due to the ongoing metabolic reactions. Some time later the action was repeated again, and so on. As a result, one has obtained the parts of the process with controlled pH, and the parts of the process with freely falling pH value (see Figure 3).

First, the equations (1)-(2) were added to the already identified model (3)-(8). Then the unknown coefficients α_1 and α_2 were identified from the pH profile, where $F_{pH} = 0$. Later on, the identified values of the parameters α_1 and α_2 are fixed and the optimal value of $C_{H^+}^0$ was calculated using the data from the periods of the process where pH was controlled.

The optimization criterion for the identification procedure was minimal RMS deviation between the modelling results and the experimentally obtained data for pH. The identified values of the parameters α_1, α_2 , and $C_{H^+}^0$ are given in Table 2. The modelling trajectories of pH showed good coincidence between the modelled and experimental results (see Figure 3). The identification of parameters α_1, α_2 and $C_{H^+}^0$ resulted in 0.012 RMS deviation for pH.

Table 2. Identified values of the pH model parameters

Model parameter	Value		Units
	Phase 1	Phase 2	
α_1	$0.422 \cdot 10^{-7}$	$0.4088 \cdot 10^{-7}$	[mol/g]
α_2	$0.011 \cdot 10^{-7}$	$0.0179 \cdot 10^{-7}$	[mol/(gh)]
$C_{H^+}^0$	$-5.367 \cdot 10^{-5}$		[mol/l]

5. Mathematical model of the adaptive control system

After the creation of the process model (1)-(8), and the identification of the unknown model parameters, a mathematical model of the adaptive pH control system was elaborated. The general structure of the adaptive pH control system applied is shown in Figure 4.

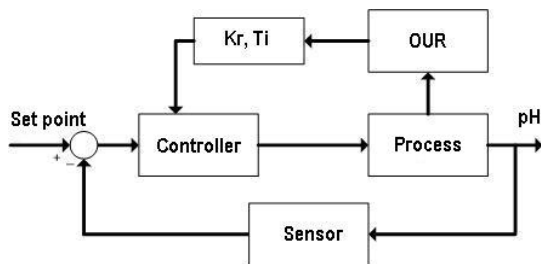

Figure 4. General structure of the adaptive pH control system

The objective of the proposed adaptive control system is to guarantee significantly lower tracking error of pH as compared to the standard PI control system, and at the same time it should maintain sufficient stability when the maximal possible disturbances of the process occur. In the controller's input the error

between the set point and the actual value is recalculated from pH to C_{H^+} . In order to investigate which of the controller parameters should be adapted online the equation (2) is linearized around the working point. Under the equilibrium conditions around the working point, the following equations are valid:

$$\frac{dC_{H^+}}{dt} = 0, \quad (9)$$

$$F_{pH}^* = \frac{(\alpha_1 \mu + \alpha_2) x V^*}{(C_{H^+}^0 - C_{H^+}^*)}. \quad (10)$$

After the linearization of (2) around the working point one gets:

$$\frac{d(\Delta C_{H^+})}{dt} = -\frac{F_{pH}^*}{V^*} (\Delta C_{H^+}) + \frac{C_{H^+}^0 - C_{H^+}^*}{V^*} \Delta F_{pH}. \quad (11)$$

Multiplication of both sides of (11) by $\frac{V^*}{F_{pH}^*}$ leads

$$\text{to:} \quad \frac{V^*}{F_{pH}^*} \frac{d(\Delta C_{H^+})}{dt} + (\Delta C_{H^+}) = \frac{C_{H^+}^0 - C_{H^+}^*}{F_{pH}^*} \Delta F_{pH}. \quad (12)$$

Equation (12) is a first order differential equation, where the object output is change of concentration ΔC_{H^+} , and the object input is change of alkali feeding rate ΔF_{pH} . The structure of the corresponding process transfer function (in Laplace transform) around the working point is

$$W(s) = \frac{\Delta C_{H^+}(s)}{\Delta F_{pH}(s)} = \frac{K_0}{T_0 s + 1}, \quad (13)$$

and the coefficients of the transfer function (13) are as follows:

$$K_0 = \frac{C_{H^+}^0 - C_{H^+}^*}{F_{pH}^*} = \frac{(C_{H^+}^0 - C_{H^+}^*)^2}{(\alpha_1 \mu + \alpha_2) x V^*}, \quad (14)$$

$$T_0 = \frac{V^*}{F_{pH}^*} = \frac{(C_{H^+}^0 - C_{H^+}^*)}{(\alpha_1 \mu + \alpha_2) x}. \quad (15)$$

Unfortunately, the process model has no clearly defined delay. Hence, for the tuning of controller parameters it is not possible to apply the empirical tuning rules involving delay.

It was shown (e.g., [3]) that for such structure of the process model the derivative part of the PID controller is not able to additionally improve the control quality as compared to a control system based on PI controller.

In order to investigate the functional relationships between the controller's tuning parameters and the process variables it is of advantage to write down the internal model control tuning rules [3]. After their simplification taking into account (14)-(15) one gets:

$$K_r = \frac{T_0}{T_f K_0} = \frac{V^*}{T_f (C_{H^+}^0 - C_{H^+}^*)^2}, \quad (16)$$

$$T_i = T_0 = \frac{(C_{H^+}^0 - C_{H^+}^*)}{(\alpha_1 \mu + \alpha_2) x}. \quad (17)$$

The final expressions in (16)-(17) show that only T_i depends on x , which is the main disturbance during the control, while K_r depends on V . Because in the analyzed case the latter variable varies during the process within a narrow range (5–5.5 [l]), its influence on K_r is relatively small. Hence, in the first simplified approach the parameter K_r can be excluded from the adaptation rules. Later on, the adaptation algorithm can be enhanced by this rule in order to make a fine tuning of the control system and additionally to improve control quality.

A possible way to calculate first guess values of K_r and T_i in the standard (non-adaptive) PID control system is an application of the Ziegler-Nichols tuning rule (sensitivity approach) [3] for PI controller:

$$K_r = 0.45K_U, \tag{18}$$

$$T_i = 0.833T_U, \tag{19}$$

where:

K_U – gain margin for loop stability;

T_U – period of the oscillation frequency at the stability limit.

In the investigated case this technique was used to calculate the initial values (at $t=0$ [h]) of parameters K_r and T_i . In order to adapt online the value of T_i it is not possible to use the values of biomass concentration x because in the analyzed case it is not measured online. Nevertheless, it is possible to use another variable that is closely correlated with x and can be

calculated or measured online, e. g., OUR . As it can be seen from (5) and (17), OUR is linearly correlated with the denominator of the tuning rule for T_i . Therefore, in order to adapt the controller parameters online by means of gain scheduling technique [3] the following empirical equation was elaborated and used:

$$T_i = \frac{\gamma_1}{\gamma_2 + OUR}, \tag{20}$$

where γ_1, γ_2 – empirical coefficients that were determined empirically during the design process.

The values obtained in the analyzed case are given in Table 3.

Table 3. Identified values of the T_i model parameters

Model parameter	Value	Units
γ_1	0.50	[g]
γ_2	4.50	[g/h]

Later on, for additional improvement of control quality the following empirical equation was used for the adaptation of K_r by means of gain scheduling technique:

$$K_r = K_{r0} \frac{V}{V_0}, \tag{21}$$

where:

V_0 – initial volume (at $t=0$ [h]);

K_{r0} – initial value of K_r (at $t=0$ [h]) calculated using Ziegler-Nichols tuning rule.

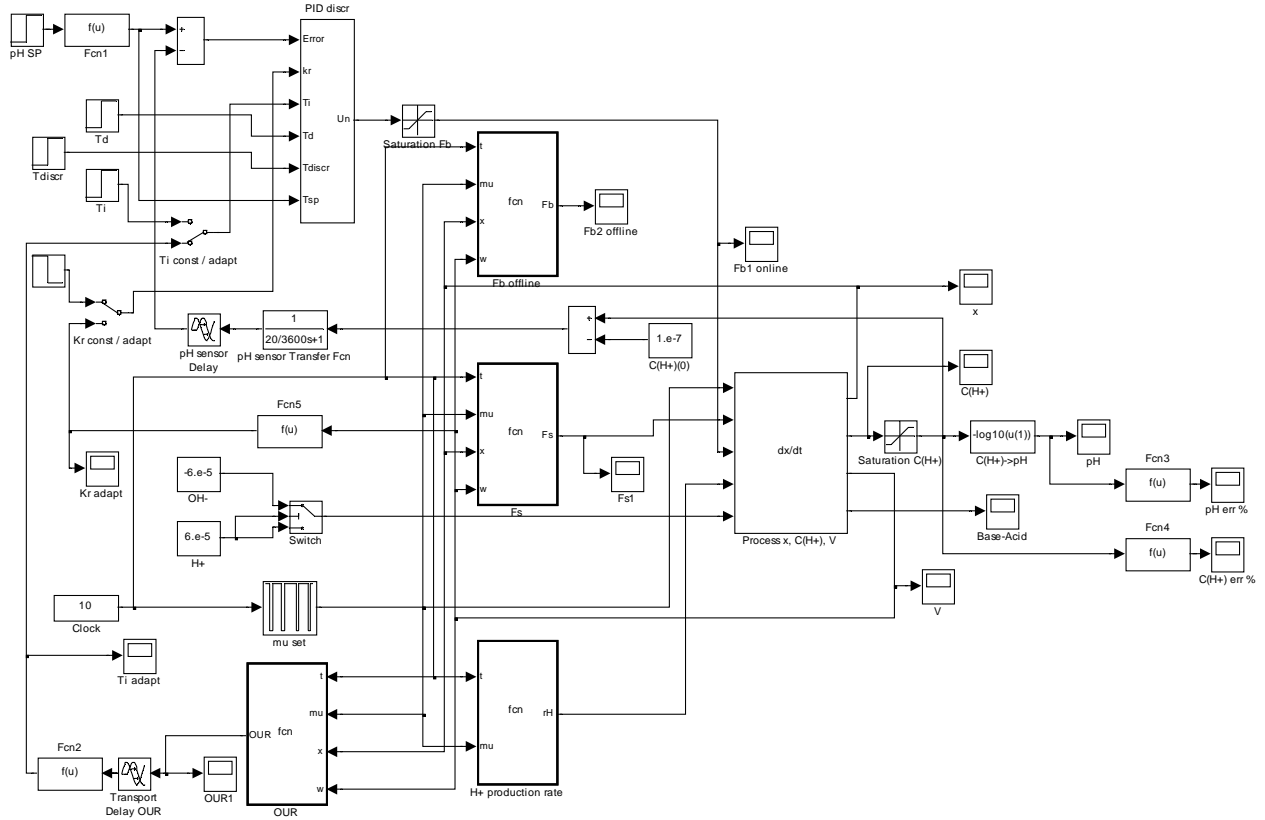

Figure 5. General view of the adaptive pH control system model

6. Results and discussion

The model of the adaptive pH control system was built using Matlab/Simulink environment. General view of the model is presented in Figure 5.

The process model consists of functional blocks for modelling of (1)-(8). Additionally, for the modelling of behaviour of the pH sensor the first order transfer function and delay were introduced. Their parameters were identified in advance. The controller implemented is a discrete PI controller that uses the deviation of the pH signal from the set point as an input. The output of the controller is alkali solution flow rate F_{pH} . Also the block for the modelling of disturbance (specific biomass growth rate, μ) was used.

The simulation was performed under the starting conditions similar to the experimental ones. The set point for pH was set to 7.0. Despite that the controller was set to work in PI mode, the tracking error was increasing due to exponentially growing biomass concentration that has acted as a disturbance.

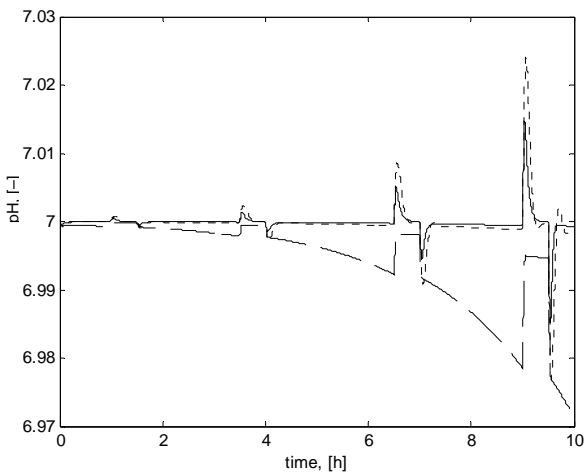

Figure 6. Tracking quality of the adaptive and standard control systems (dashed line – standard PI; dotted line – with adaptive T_i ; solid line – with adaptive T_i and K_r)

The simulation results (see Figure 6) show that the tracking error of both investigated adaptive PI controllers (with one and two adaptive parameters, respectively) was significantly lower than the one in the case of a PI controller with constant tuning parameters. The signal of the controller output (alkali solution flow rate) is shown in Figure 7.

At the end of the process the adaptive controllers still were able to keep pH value of ~ 6.999 as compared to 6.97 in the case of the control system based on the standard PI controller. One can show that with the increasing amount of biomass in the bioreactor at the end of the process the pH level rapidly decreases and reaches the value of, e. g. ~ 6.9 at $t=12$ [h] in case of standard PI control. Nevertheless, using the adaptive control system it is possible to keep this value at 6.998.

The tuning parameters of the standard PI control system were chosen taking into account the dynamics

of the control object at the beginning of the process. If one tries to reduce the tracking error at the end of the process and tunes the controller parameters on the basis of the process dynamics at the end (at $t=10$ [h]), and uses these values during the whole process, it can lead to instability of the control system. Hence, the only solution is to gradually adapt the value of T_i . The evolution of T_i according to (20) during the adaptive pH control process is shown in Figure 8. Additionally, the simulation with two adaptive parameters (T_i and K_r) was performed (see Figures 6-8).

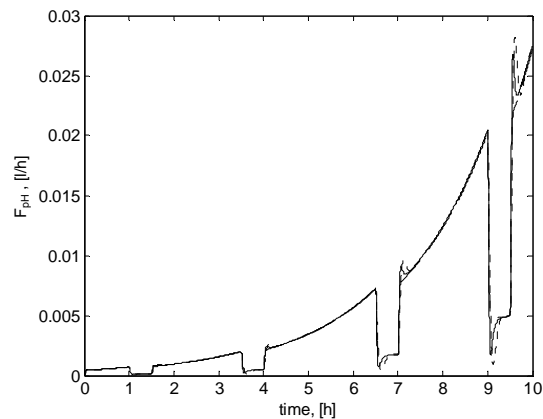

Figure 7. Output of the controller (alkali solution flow rate) of the adaptive and standard control systems (dashed line – standard PI; dotted line – with adaptive T_i ; solid line – with adaptive T_i and K_r)

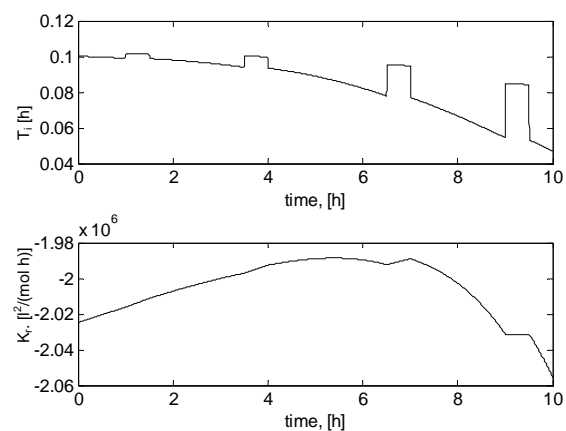

Figure 8. The evolution of T_i and K_r values during the control using the adaptive control system

During the 1–1.5, 3.5–4, 6.5–7, and 9–9.5 [h] of the process the disturbance in form of stepwise reduced biomass specific growth rate was introduced (both times from 0.5 to 0.1 [1/h], and vice versa). This is a typical case in practice when substrate or oxygen supply is disrupted due to malfunction of the equipment. At the same time this kind of disruption proved to be the most significant disturbance of the process. In order to keep the desired pH level an appropriate action of the pH controller is required. The simulation results (see Figure 6) show that in the case of adaptive control (with adaptive T_i) the overshoot was about

30 % smaller, and the tracking error during the introduced disturbance was of the magnitude lower.

The control quality in the case of adaptive parameters T_i and K_r is further improved by reducing the tracking error and the overshoots during the presence of disturbance (see Figure 6). This proves once more the effectiveness of the proposed adaptive control approach.

7. Conclusions

The simulation tests of the adaptive control system were performed taking into account the process actuators' nonlinearities that apply in the real process. Moreover, the control system was tested in a wide range of disturbances, which are typical to the process and which affect the control quality and stability. The only factor that was not considered during the simulation was measurement noise. The influence of this factor will be tested on a real control system. The proposed adaptive control algorithm was simulated under typical and extreme operating conditions of the control system and it has proved to be a robust and stable solution ensuring high quality pH control under the tested conditions of the analyzed biochemical fed-batch process. Nevertheless, further experimental investigations should be carried out in order to implement the proposed approach into a real control system and to perform extensive tests with the proposed adaptive control system, which could become a real alternative to standard PID control system.

References

- [1] **K.G. Carr-Brion (Ed.)**. Measurement and Control in Bioprocessing. *Elsevier Science Publishers, London*, 1991.
- [2] **M.A. Henson, D.E Seborg**. Adaptive Nonlinear Control of a pH Neutralization Process. *IEEE Transactions on Control Systems Technology*, 1994, *Vol.2, Issue 3*, 169-182.
- [3] **W.S. Levine (Ed.)**. The Control Handbook. *IEEE/CRC Press*, 1996.
- [4] **L. Ljung**. System Identification: Theory for the User (2nd Edition). *Prentice Hall, New Jersey*, 1999.
- [5] **G.K. McMillan, R.A. Cameron**. Advanced pH Measurement and Control. *ISA*, 2005.
- [6] **S.A. Siano**. On the Use of the pH Control Reagent Addition Rate for Fermentation Monitoring. *Biotechnology and Bioengineering*, 1995, *Vol.47, No.6*, 651-665.
- [7] **B. Sonnleitner**. Instrumentation of Biotechnological Processes. *Advances in Biochemical Engineering/ Biotechnology*, 2000, *Vol.66*, 1-64.
- [8] **T. Ylöstalo, H. Hyötyniemi, P. Jutila, J.-P. Ylen, G.P. Rangaiah**. Comparison of Practical Adaptive Algorithms in pH Control. Commentary. *European Journal of Control*, 2001, *Vol. 7, No.5*, 463-475.

Received April 2009.

DOI: 10.5755/j01.itc.38.3.12103