

A NEW TECHNIQUE APPLIED TO A FUZZY REGULATOR TO CONTROL THE SHUNT ACTIVE FILTER DC BUS VOLTAGE

Othmane Abdelkhalek, Chellali Benachaiba, Mohammed Haidas

*Laboratory of Power Quality and Artificial Intelligence, Bechar University Centre
BP 417 Bechar 08000, Algeria*

Tarak Benslimane

University of Boumerdes, Algeria

Abstract. This paper presents a shunt active power filter to compensate reactive power and reduce the unwanted harmonics. A shunt active filter is realized employing three-phase voltage source inverter (VSI) bridge with common DC bus condenser. The shunt active filter acts as a current source, which is connected in parallel with a nonlinear load and controlled to generate the required compensation currents.

To shorten the rise of the regulated condenser voltage, adjust the Fuzzy Logic Controller (FLC) coefficient.

Regulation of condenser voltage based on Fuzzy Logic Regulator (FLC) constant coefficient may improve the transient response of voltage regulation but it has a bad impact on the THD of supply phases currents.

In this paper, a method is proposed based on FLC with variable coefficient in the aim of shortening the rise time of the regulated condenser voltage and improvement the THD of supply currents.

Simulation results are presented to confirm the validity of the proposed technique.

Keywords: Active power filter; Current control; DC bus voltage fuzzy logic controller (FLC).

1. Introduction

The use of power electronic systems is growing in all branches of industry as well as general consumers of electric energy. It is well known that these systems such as AC-DC converters are considered as nonlinear loads, generating high harmonic currents and reducing input power factor. Therefore, compensation methods aiming at elimination of these harmonic currents and achieving unity power factor have become an important issue recently. In order to overcome these problems simultaneously, numerous active filtering methods have been developed in recent years [1]. In general, there are two types of active filters: the shunt type and the series type. The shunt active power filter based on the voltage-source PWM converter topology is the most widely used active filter and is recognized as a viable solution due to its excellent performance characteristics and simplicity in the implementation, both in single- and three-phase configurations

This paper presents fuzzy control applicable for active power filter for three-phase systems, which are comprised of nonlinear loads. The active filter is based on a three-phase inverter with six controllable switches. The AC side of the inverter is connected in parallel with the other nonlinear loads through a filter inductance. The DC side of the inverter is connected

to a filter condenser. The Fuzzy Controller (FC) is used to control of DC bus voltage.

Simulation results will be presented and discussed.

2. Fuzzy logic

When designing the control of an industrial process, its dynamic model is required first. Sometimes, the model of a system may not be possible in practice. There are some processes, which can be modeled, but their parameters may be changed from time to time. In these cases, to solve the problems occurring and to model the system, the knowledge and experiences of expert persons are used. Expert persons can use some linguistic definitions for modeling and solving problems, such as negative large (NL), negative medium (NM), negative small (NS), zero (Z), positive small (PS), positive medium (PM) and positive large (PL) [1].

Lutfi A. Zadeh from the University of California first introduced fuzzy logic theory in 1965.

Fuzzy logic theory has been implemented successfully in several applications. Recently, fuzzy logic theory has been used frequently to increase the power capacity, stability and efficiency of power systems [3].

When designing a fuzzy logic controller, the information obtained from the operator is more important than the dynamic mathematical model of the system [1]. The real problem in a control system is the output signal or error signal in the physical environment. This information plays an important role in the processes of closed loop systems because the closed loop systems are commanded according to this information.

The aim of fuzzy logic control is to reduce the error of the system to a minimum. The size of the controller input is associated with the size of error. The rate of change of error affects the determination of the controller input. Therefore, as the linguistic changes, the error and the change of error are used to give the decision according to the controller rules [1, 5].

The most important state for solving a problem by using fuzzy logic theories is the determination of the membership functions. In many studies, it has been shown that the degree of membership of a fuzzy logic set is directly related to the senses obtained from samples in some applications. In other applications, it is related to statistical or mathematical estimations under specific assumptions.

2.1. Fuzzy logic controller

Fuzzy logic can be considered as a special class of symbolic controllers. The three main features of symbolic controllers become fuzzification (for the numeric to symbolic interface), fuzzy inference (for the decision system), and defuzzification (for the symbolic to numeric interface) [4].

The inputs and outputs of the fuzzy controller are expressed in several linguistic levels, such as positive big (PB), positive small (PS), zero (Z), negative medium (NM) etc. Each level is described by a fuzzy set.

For this study, the fuzzy block has two inputs: the load current (I_L) and the power factor error (e). The output (control action) is the change of excitation current (ΔI_f). Figure 1 shows the configuration of the fuzzy block.

2.1.1. Fuzzification

All crisp input values must be converted to fuzzy sets before being used. This process is called the fuzzification operation, and a fuzzy set is characterized by a membership function [6].

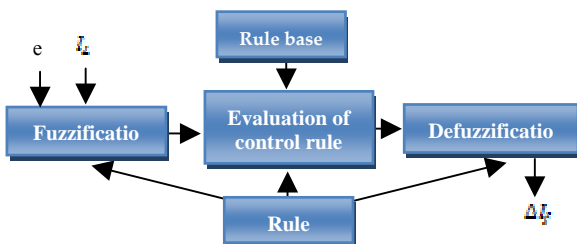

Figure 1. The configuration of the fuzzy block

Most of the membership functions are associated with terms that appear in the antecedents or consequence of rules. The membership function is a graphical representation of the magnitude of participation of each input. It associates a weighting with each of the inputs processed, defines functional overlap between inputs and ultimately determines an output response.

The fuzzification process requires strong understanding of the classification of all variables. In general, experience and expertise are required for implementation of fuzzification in complex control systems [6].

2.1.2. Fuzzy inference

The heart of a fuzzy logic controller is its inference engine where the knowledge base and decision-making logic reside [5]. The database and the rule base form the knowledge base. The database contains a description of the input and output variables using fuzzy sets with membership functions. Construction of the database involves designing the universe of discourse (which provides the set of allowable values for a variable) for each variable, determining the number of fuzzy sets and designing the membership functions. The rule base is a collection of fuzzy conditional statements based on the control objectives and control policy given by the domain expert.

2.1.3. Defuzzification

The output of the inference mechanism is a fuzzy set on the output universe of discourse, so there is a need for converting the output of the fuzzy controller (a fuzzy set) to a crisp value required by the plant. This is called the defuzzification operation, and can be performed by a number of methods of which the center of gravity (also known as centroid) and height methods are common [6].

3. Active power filter topology

In this paper the shunt active filter has three wires, which involve six switches (three lags), one condenser in the DC side.

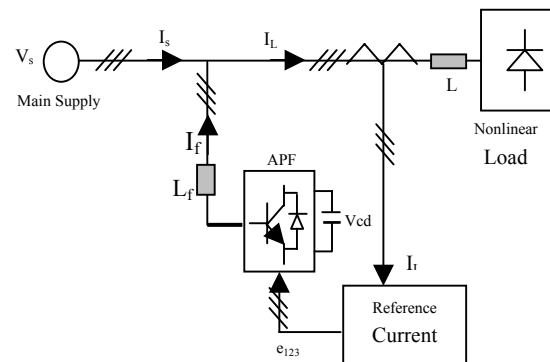

Figure 2. The connection of the shunt active filter

Figure 2 shows a block diagram of the parallel active filter connection. It consists of a DC link inverter and filter section, controller and feedback signals. The filter inductor is used to convert the voltage source inverter output to a current source capable of injecting harmonic currents (I_f) to the load. The configuration exhibited in Figure 2 uses load current feedback.

4. DC bus voltage regulation

The energy source associated with the inverter is a condenser. So that the injection of a reference current in each of the phases is possible, the tension in the borders of this condenser must be constant and fixed to a value predetermined to assure the role of a continuous voltage source (Figure 3).

The active power losses in the active filter (the losses by commutation of switches and the losses by Joule effect in the exit filter components) are the main causes susceptible to modify the voltage.

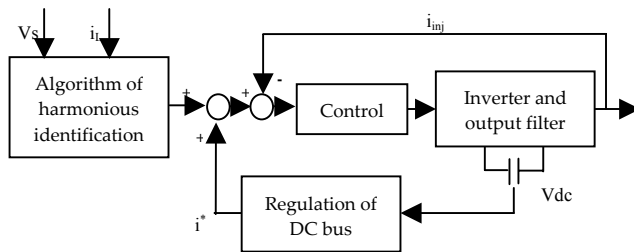

Figure 3. Principal scheme of the inverter commands part with the condenser voltage control

The average voltage regulation in the borders of the energy storage condenser has to be made by the addition of the active current not producing reactive power.

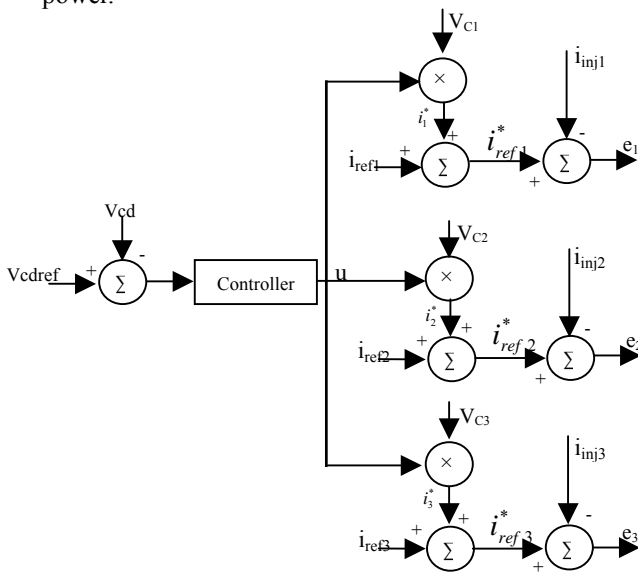

Figure 4. Principal scheme of the three phase's voltage controller

The technique which we used to control the voltage in the borders of the condenser is a PI controller associate in the inverter MLI command.

The following elements are necessary: – A voltage isolated probe to measure the voltage Vcd in the borders of the condenser, – A sinusoidal voltage generator of unit amplitude V, in phase with the network voltage direct component, – A PI controller to maintain the condenser voltage Vcd in a fixed voltage reference Vdcref. To charge the condenser, it is necessary to be supplied with electric power coming inevitably from electric power network. Harmonic active power is added to the voltage regulator output (Figure 4) giving a place to a supplementary fundamental active current (i^*) correcting the continues voltage Vcd.

The measured voltage value Vcd is subtracted from the voltage reference Vdcref, in a way that the voltage error can be cancelled by the PI corrector action. The exit of corrector is an image of the active fundamental current amplitude necessary to correct the condenser voltage.

If this voltage is lower than the reference, it means that the real power is not sufficient. That is why the current and the real power of the network are increased. Also, If the condenser voltage is superior to the reference, the network current amplitude must be reduced to limit the supplied real power.

The u signal at the exit of the PI is multiplied by the voltage $-v_{c1}$ in opposition in phase with the network fundamental voltage. Because of the active filter action, this voltage is also in opposition in phase with the network fundamental current.

The current i_1^* so obtained is added to the harmonious currents of compensation identified on the electrical network. The new compensation current i_{ref1}^* will be the new reference for the command of the inverter. The same process is repeated for two other phases. We are thus going to impose the variation of necessary current (and thus variation of necessary active power) in the condenser to reach the fixed reference voltage.

4.1. The controller

In this paper, we proposed a fuzzy regulator with a single entry of gain k_1 and a single exit of gain k_2 . We supposed k_1 constant equal to 1 and k_2 vary according to time.

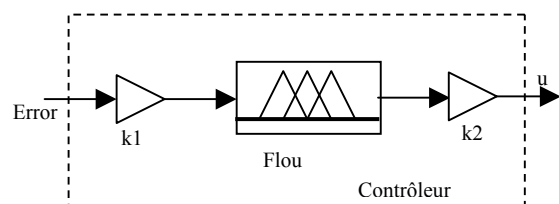

Figure 5. The Fuzzy controller

Our simulation is dividing into two parts. In the first part (Figure 5) we used a fuzzy controller with two gains, input gain ($k_1 = 1$) and constant output gain k_2 with several values (Table 1).

For the second part (Figure 6), we supposed that k_1 is equal to 1 but k_2 is variable.

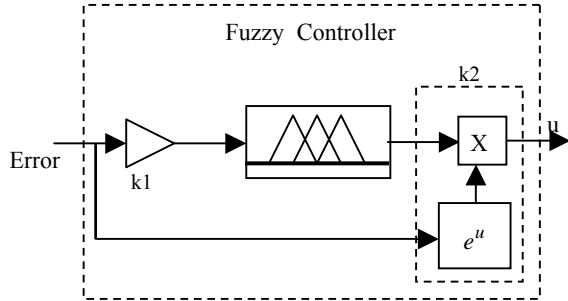

Figure 6. The modified fuzzy controller

4.1.1. The first part

Table 1

Case	k_2	THD(%)	tr(s)
1	1	2.40	0.07
2	5	2.57	0.053
3	11	2.67	0.0335
4	15	8.75	0.280
5	20	13.37	0.0225
6	25	16.01	0.019
7	35	27.63	0.0152
8	40	28.55	0.014
9	45	30.51	0.013
A	No	3.08	0.0095

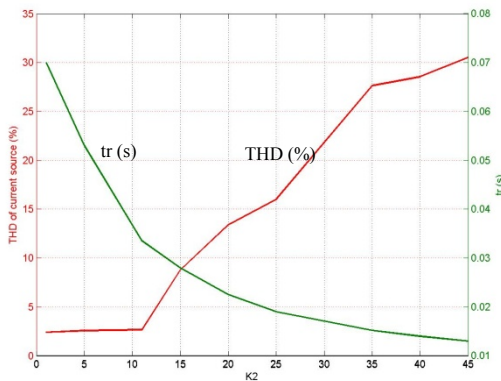

Figure 7. The variation of the THD value (THD(%)) and the response time (tr(s)) according to the variation of the gain k_2

Figure 7, shows the variation of time rise (tr) and supply currents THD according to the gain k_2 . The increase of gain k_2 shorten the time response of regulated voltage but it causes the increase of filtered currents THD. It is important to notice that the supply current THD is limited to 5% according to the IEEE standards [7].

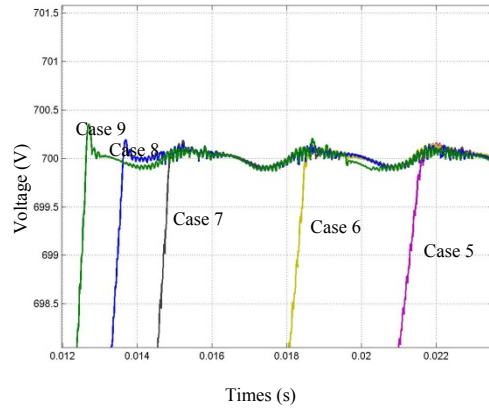
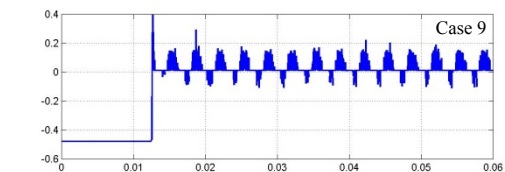
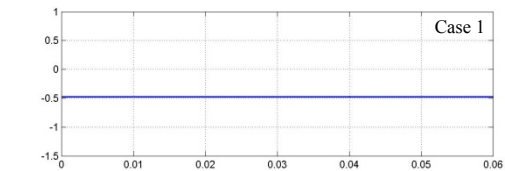
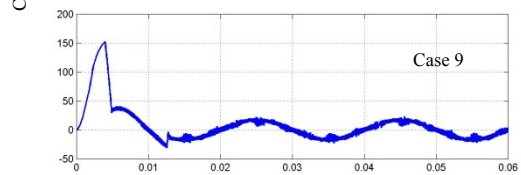
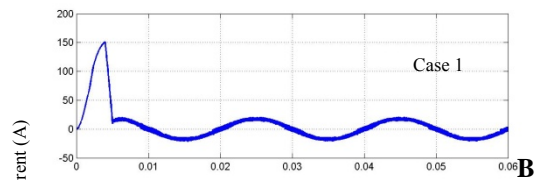
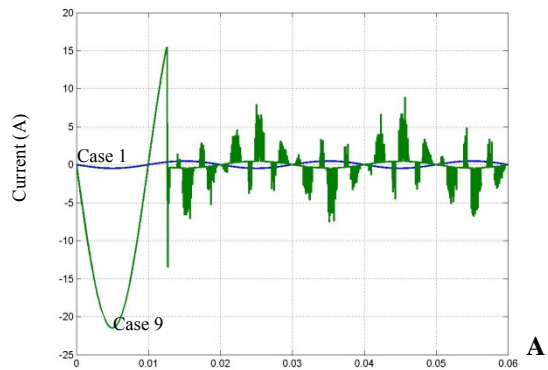

Figure 8. The controlled condenser voltage



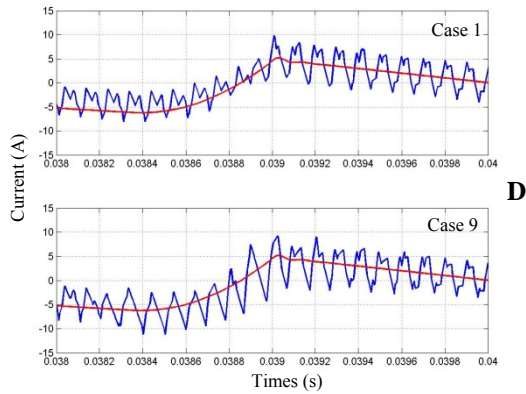

Figure 9. A comparison between the case 1 and the case 9

- A: the compensated current (i_1^*)
- B: the source current phase a
- C: output signal of the Fuzzy regulator
- D: the reference current and the injected current

According to Figure 8, we notice different time response for the regulated Vdc voltage. We consider for example the case 9 and the case 3 (Table1). In the case 9, time response ($t_r = 0.013$ s) but THD is equal to 30.51%. In case 3, the THD is equal to 2.67 % but time response ($t_r = 0.033$ s).

Figure 9 shows the simulation results obtained in case 1 with gain k_2 equal to 1 and in case 9 with gain k_2 equal to 45. In case 9, the inverter condenser is quickly charged (Figure 8) thanks to the important compensated current (i_1^*) (Figure 9A). In case 1, the inverter condenser is slowly charged (Table 1) due to the low value of compensated current (i_d) (Figure 9 A).

On the other hand, the important value of the gain k_2 yield an undesirable high frequency compensated current (Figure 9A and Figure 9C) infecting the supply current (Figure 9B and Figure 9D).

4.1.2. The second part

According to results of the part 1, we can conclude that the important value of k_2 allows a quick charging of the condenser but it influences negatively on the filtered current quality. On the other hand, the low value of k_2 causes a slow charging of the condenser and it has no negative impact of the filtered current quality.

On the lighting of this result, we propose that the value of k_2 varies according to two intervals. In the first interval (transient mode interval), we interested in a very short condenser charging time which means an important value of k_2 . In the second interval (stationary mode interval), we are interested in the supply current quality which means a low value of k_2 .

In our solution, we proposed that the gains k_2 follow an exponential function (Figure 10).

Figure 11 represents the controlled voltage in the borders of the condenser. We compared between the

case 9 and the case A (the case A presents the proposed solution). It seems clearly that the proposed solution is characterized by a very low time response (t_r is equal to 0.0095 s) compared to the case 9 (t_r is equal to 0.013 s). The case A presents acceptable results at the level of THD. The THD measured for the case 9 is equal to 30.51 %. On the other hand we have a THD equal to 3.08 % for the proposed solution case.

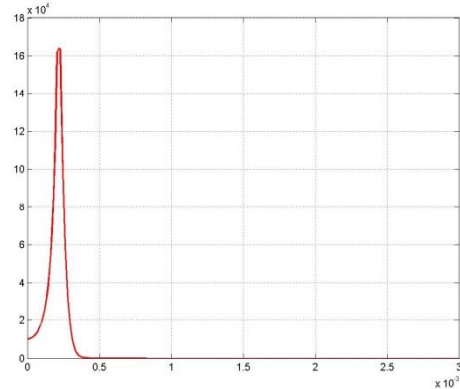

Figure 10. Variation of the gain k_2

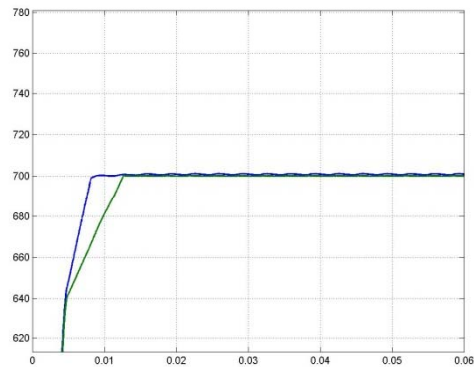

Figure 11. Condenser regulated voltages

5. Conclusion

The studied FLC regulator is based on one input signal (error) and one output signal. The technique of realization of the membership function is easy, but the problem settles for the adequate choice of gain. This operation asks for a considerable experience. According to the simulation results, it is noticed that the choice of gain has a big influence on the initial condenser charging time and on the quality of filtered current. With this fuzzy controller, it is not possible to improve at the same time both parameters. The proposed solution based on variable FLC gain offers a considerable improvement of both parameters at the same time.

References

- [1] C. Benachaiba, S. Dib, O. Abdelkhalek. Genetic algorithm-based self-learning fuzzy pi controller for shunt active filter. *International Journal of Applied Engineering Research*, Vol.1, No.2, 2006, 203-216.

- [2] **C. Benachaiba, O. Abdelkhalek, S. Dib, M. Haidas.** Optimization of parameters of the unified power quality conditioner using genetic algorithm method. *Information Technology And Control*, 2007, Vol.36, No.2, 242-245.
- [3] **M. George.** Artificial intelligence based three-phase unified power quality conditioner. *Journal of Computer Science*, Vol.3, No.7, 2007, 465-477.
- [4] **C.Sharmeela, M.R.Mohan, G.Uma, J.Baskaran.** Fuzzy logic controller based three-phase shunt active filter for line harmonics reduction. *Journal of Computer Science*, Vol.3, No.2, 2007, 76-80.
- [5] **I. Iskender, A. Karaarslan.** On the comparison of fuzzy logic and state space averaging based sliding control methods applied on an arc welding machine. *Proceedings Of World Academy Of Science, Engineering And Technology*, Vol.8, 2005, 100-105.
- [6] **S. H. Hosseini, M. A. Badamchizadeh.** A fuzzy power control for three phase pwm rectifier with active filtering function. *June 2-5, 2005, KINTEX, Gyeonggi-Do, Korea.*
- [7] IEEE Standard 519-1992. *Recommended Practices and Requirements for Harmonic Control in Electrical Power Systems*, The Institute of Electrical and Electronics Engineers, 1993.

Received February 2008.

DOI: 10.5755/j01.itc.37.3.11941