

# COMPOSITION OF AUGMENTED MARKED GRAPHS AND ITS APPLICATION TO COMPONENT-BASED SYSTEM DESIGN

**K.S. Cheung**

*Hong Kong Baptist University  
Kowloon Tong, Hong Kong*

**Abstract.** Augmented marked graphs possess some structural characteristics which are especially desirable for modelling systems with common resources. This paper first investigates the composition of augmented marked graphs via common resource places. Special focus is placed on preservation of four properties, namely, liveness, boundedness, reversibility and conservativeness. It is then applied to component-based system design, where the system components are specified as augmented marked graphs and composed via their common resource places. Based on the preservation of properties of this composition, the liveness, boundedness, reversibility and conservativeness of the integrated system can be readily derived. Examples of manufacturing system integration are used for illustration.

**Keywords:** Petri net, augmented marked graph, component-based design, system synthesis.

## 1. Introduction

A subclass of Petri nets, augmented marked graphs possess a structure especially for modelling systems with common resources. They also exhibit a number of desirable properties pertaining to deadlock-freeness, liveness, boundedness, reversibility and conservativeness. Chu and Xie first investigated their deadlock-freeness, liveness and reversibility using siphons and mathematical programming [1]. The author earlier proposed some siphon-based and cycle-based characterisations for live and reversible augmented marked graphs, and transform-based characterisations for bounded and conservative augmented marked graphs [2, 3, 4]. Besides, Huang investigated the property-preserving composition for augmented marked graphs [5].

This paper first investigates the composition of augmented marked graphs via common resource places, with a focus on preservation of properties. These properties include liveness, boundedness, reversibility and conservativeness. Liveness implies deadlock-freeness. Boundedness implies absence of capacity overflow. Reversibility refers to the capability of being reinitialised. They collectively characterise a robust or well-behaved system. Next, we show how this composition of augmented marked graphs can be effectively applied to component-based system design.

Typically in component-based system design, a system is synthesised from a set of components through composition. By modelling the components as augmented marked graphs and composing them via their common resource places, which represent

common resources, an integrated system is obtained. Then, based on the property-preservation of this composition, the liveness, boundedness, reversibility and conservativeness of the integrated system can be readily derived.

After a brief review of augmented marked graphs, this paper describes the composition of augmented marked graphs via common resource places, and specifically show that this composition preserves boundedness and conservativeness whereas liveness and reversibility can be preserved under a pretty simple condition. The results are then applied to component-based system design and illustrated with examples of manufacturing system integration.

The rest of this paper is organised as follows. Section 2 provides the preliminaries to be used. Section 3 introduces augmented marked graphs and summarises their properties. Section 4 describes the composition of augmented marked graphs and study the preservation of properties in the composition process. Section 5 shows its application to the component-based system design and illustrates with examples. Section 6 briefly concludes this paper.

## 2. Preliminaries

This section provides the preliminaries to be used in this paper for readers who are not familiar with Petri nets [7, 8, 9].

A place-transition net (PT-net) is a directed graph consisting of two sorts of nodes called places and transitions, such that no arcs connect two nodes of the

same sort. Graphically, a place is denoted by a circle, a transition by a box or a bar, and an arc by a directed line. A Petri net is a PT-net with tokens assigned to its places, and the token distribution over its places is denoted by a marking function.

**Definition 2.1.** A place-transition net (PT-net) is a 4-tuple  $N = \langle P, T, F, W \rangle$ , where  $P$  is a set of places,  $T$  is a set of transitions,  $F \subseteq (P \times T) \cup (T \times P)$  is a flow relation and  $W : F \rightarrow \{1, 2, \dots\}$  is a weight function.  $N$  is said to be an ordinary PT-net if and only if  $W : F \rightarrow \{1\}$ .

An ordinary PT-net can be written as  $\langle P, T, F \rangle$ . In the rest of this paper, unless specified otherwise, all PT-nets are ordinary.

**Definition 2.2.** Let  $N = \langle P, T, F, W \rangle$  be a PT-net. For  $x \in (P \cup T)$ ,  $\bullet x = \{y \mid (y, x) \in F\}$  and  $x^\bullet = \{y \mid (x, y) \in F\}$  are called the pre-set and post-set of  $x$ , respectively. For  $X = \{x_1, x_2, \dots, x_n\} \subseteq (P \cup T)$ ,  $\bullet X = \bullet x_1 \cup \bullet x_2 \cup \dots \cup \bullet x_n$  and  $X^\bullet = x_1^\bullet \cup x_2^\bullet \cup \dots \cup x_n^\bullet$  are called the pre-set and post-set of  $X$ , respectively.

**Definition 2.3.** For a PT-net  $N = \langle P, T, F, W \rangle$ , a path is a sequence of nodes  $\rho = \langle x_1, x_2, \dots, x_n \rangle$ , where  $(x_i, x_{i+1}) \in F$  for  $i = 1, 2, \dots, n-1$ .  $\rho$  is said to be elementary if and only if it does not contain the same node more than once.

**Definition 2.4.** For a PT-net  $N = \langle P, T, F, W \rangle$ , a cycle is a sequence of places  $\langle p_1, p_2, \dots, p_n \rangle$  such that  $\exists t_1, t_2, \dots, t_n \in T : \langle p_1, t_1, p_2, t_2, \dots, p_n, t_n \rangle$  forms an elementary path and  $(t_n, p_1) \in F$ .

**Definition 2.5.** For a PT-net  $N = \langle P, T, F, W \rangle$ , a marking is a function  $M : P \rightarrow \{0, 1, 2, \dots\}$ , where  $M(p)$  is the number of tokens in  $p$ .  $(N, M_0)$  represents  $N$  with an initial marking  $M_0$ .

**Definition 2.6.** For a PT-net  $N = \langle P, T, F, W \rangle$ , a transition  $t$  is said to be enabled at a marking  $M$  if and only if  $\forall p \in \bullet t : M(p) \geq W(p, t)$ . On firing  $t$ ,  $M$  is changed to  $M'$  such that  $\forall p \in P : M'(p) = M(p) - W(p, t) + W(t, p)$ . In notation,  $M [N, t] M'$  or  $M [t] M'$ .

**Definition 2.7.** For a PT-net  $(N, M_0)$ , a sequence of transitions  $\sigma = \langle t_1, t_2, \dots, t_n \rangle$  is called a firing sequence if and only if  $M_0 [t_1] \dots [t_n] M_n$ . In notation,  $M_0 [N, \sigma] M_n$  or  $M_0 [\sigma] M_n$ .

**Definition 2.8.** For a PT-net  $(N, M_0)$ , a marking  $M$  is said to be reachable if and only if there exists a firing sequence  $\sigma$  such that  $M_0 [\sigma] M$ . In notation,  $M_0 [N, *] M$  or  $M_0 [*] M$ .  $[N, M_0]$  or  $[M_0]$  represents the set of all reachable markings of  $(N, M_0)$ .

**Definition 2.9.** Let  $N = \langle P, T, F, W \rangle$  be a PT-net, where  $P = \{p_1, p_2, \dots, p_m\}$  and  $T = \{t_1, t_2, \dots, t_n\}$ . The incidence matrix of  $N$  is an  $m \times n$  matrix  $V$  whose typical entry  $v_{ij} = W(p_i, t_j) - W(t_j, p_i)$  represents the change in number of tokens in  $p_i$  after firing  $t_j$  once, for  $i = 1, 2, \dots, m$  and  $j = 1, 2, \dots, n$ .

**Definition 2.10.** A marked graph is an ordinary PT-net  $N = \langle P, T, F, W \rangle$  such that  $\forall p \in P : |\bullet p| = |p^\bullet| = 1$ .

Liveness, boundedness, reversibility and conservativeness are four well-known properties of Petri nets, used for describing a robust or well-behaved system. Liveness implies deadlock freeness. Boundedness refers to the property that the system is free from any capacity overflow. Conservativeness is a special case of boundedness. Reversibility refers to the capability of being reinitialised from any reachable state.

**Definition 2.11.** For a PT-net  $(N, M_0)$ , a transition  $t$  is said to be live if and only if  $\forall M \in [M_0], \exists M' : M [*] M' [t]$ .  $(N, M_0)$  is said to be live if and only if every transition is live.

**Definition 2.12.** For a PT-net  $(N, M_0)$ , a place  $p$  is said to be  $k$ -bounded (or bounded) if and only if  $\forall M \in [M_0] : M(p) \leq k$ , where  $k > 0$ .  $(N, M_0)$  is said to be  $k$ -bounded (or bounded) if and only if every place is  $k$ -bounded (or bounded).

**Definition 2.13.** A PT-net  $(N, M_0)$  is said to be safe if and only if every place is 1-bounded.

**Definition 2.14.** A PT-net  $(N, M_0)$  is said to be reversible if and only if  $\forall M \in [M_0] : M [*] M_0$ .

**Definition 2.15.** A PT-net  $N = \langle P, T, F, W \rangle$  is said to be conservative if and only if there exists a  $m$ -vector  $\alpha > 0$  such that  $\alpha V = 0$ , where  $m = |P|$  and  $V$  is the incidence matrix of  $N$ .

Figure 1 shows a PT-net which is live, bounded, safe, reversible and conservative.

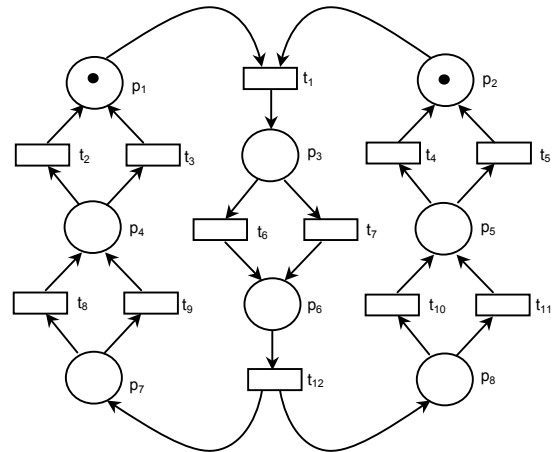

Figure 1. A live, bounded, safe, reversible and conservative PT-net

### 3. Augmented marked graphs

This section briefly describes augmented marked graphs and summarises their known properties.

**Definition 3.1** [1]. An augmented marked graph  $(N, M_0; R)$  is a PT-net  $(N, M_0)$  with a specific subset of places  $R$  called resource places, satisfying that : (a) Every place in  $R$  is marked by  $M_0$ . (b) The net  $(N', M_0')$  obtained from  $(N, M_0; R)$  by removing the places

in  $R$  and their associated arcs is a marked graph. (c) For each  $r \in R$ , there exist  $k_r \geq 1$  pairs of transitions  $D_r = \{ \langle t_{s1}, t_{h1} \rangle, \langle t_{s2}, t_{h2} \rangle, \dots, \langle t_{skr}, t_{hkr} \rangle \}$  such that  $r^* = \{ t_{s1}, t_{s2}, \dots, t_{skr} \} \subseteq T$  and  ${}^*r = \{ t_{h1}, t_{h2}, \dots, t_{hkr} \} \subseteq T$  and that, for each  $\langle t_{si}, t_{hi} \rangle \in D_r$ , there exists in  $N'$  an elementary path  $\rho_{ri}$  connecting  $t_{si}$  to  $t_{hi}$ . (d) In  $(N', M_0')$ , every cycle is marked and no  $\rho_{ri}$  is marked.

Figure 2 shows an augmented marked graph  $(N, M_0; R)$ , where  $R = \{ r_1, r_2 \}$ .

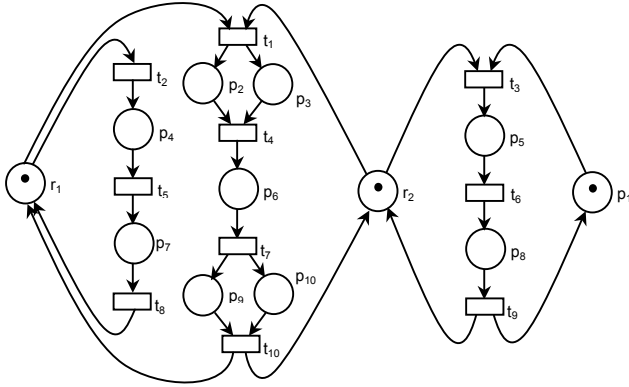

Figure 2. An augmented marked graph

**Definition 3.2.** For a PT-net  $(N, M_0)$ , a set of places  $S$  is called a siphon if and only if  ${}^*S \subseteq S^*$ .  $S$  is said to be minimal if and only if there does not exist a siphon  $S'$  in  $N$  such that  $S' \subset S$ .  $S$  is said to be empty at a marking  $M \in [M_0]$  if and only if  $S$  contains no places marked by  $M$ .

**Definition 3.3.** For a PT-net  $(N, M_0)$ , a set of places  $Q$  is called a trap if and only if  $Q^* \subseteq {}^*Q$ .  $Q$  is said to be maximal if and only if there does not exist a trap  $Q'$  in  $N$  such that  $Q \subset Q'$ .  $Q$  is said to be marked at a marking  $M \in [M_0]$  if and only if  $Q$  contains a place marked by  $M$ .

**Property 3.1** [1]. An augmented marked graph is live and reversible if and only if it does not contain any potential deadlock. (Note : A potential deadlock is a siphon which would eventually become empty.)

**Definition 3.4.** For an augmented marked graph  $(N, M_0; R)$ , a minimal siphon is called a R-siphon if and only if it contains at least one place in  $R$ .

**Property 3.2** [1, 2, 3]. An augmented marked graph  $(N, M_0; R)$  is live and reversible if every R-siphon contains a marked trap.

**Property 3.3** [2, 3]. An augmented marked graph  $(N, M_0; R)$  is live and reversible if and only if no R-siphons eventually become empty.

**Definition 3.5** [4]. Suppose an augmented marked graph  $(N, M_0; R)$  is transformed into a PT-net  $(N', M_0')$  as follows. For each  $r \in R$ , where  $D_r = \{ \langle t_{s1}, t_{h1} \rangle, \langle t_{s2}, t_{h2} \rangle, \dots, \langle t_{skr}, t_{hkr} \rangle \}$ , replace  $r$  with a set of places  $\{ q_1, q_2, \dots, q_{kr} \}$  such that  $M_0'[q_i] = M_0[r]$  and  $q_i^* = \{ t_{si} \}$

and  ${}^*q_i = \{ t_{hi} \}$  for  $i = 1, 2, \dots, k_r$ .  $(N', M_0')$  is called the R-transform of  $(N, M_0; R)$ .

**Property 3.4** [4]. Let  $(N, M_0; R)$  be an augmented marked graph, and  $(N', M_0')$  be its R-transform.  $(N, M_0; R)$  is bounded and conservative if and only if every place in  $(N', M_0')$  belongs to a cycle.

The augmented marked graph  $(N, M_0; R)$  shown in Figure 2 contains eight R-siphons :  $\{ r_1, p_2, p_4, p_6, p_7, p_9 \}$ ,  $\{ r_1, p_2, p_4, p_6, p_7, p_{10} \}$ ,  $\{ r_1, p_3, p_4, p_6, p_7, p_8 \}$ ,  $\{ r_1, p_3, p_4, p_6, p_7, p_{10} \}$ ,  $\{ r_2, p_2, p_5, p_8, p_9 \}$ ,  $\{ r_2, p_2, p_5, p_6, p_8, p_{10} \}$ ,  $\{ r_2, p_3, p_5, p_6, p_8, p_9 \}$  and  $\{ r_2, p_3, p_5, p_6, p_8, p_{10} \}$ . Each R-siphon contains a marked trap and would never become empty. According to Properties 3.2 and 3.3,  $(N, M_0; R)$  is live and reversible. As every place in the R-transform of  $(N, M_0; R)$  belongs to a cycle, according to Property 3.4,  $(N, M_0; R)$  is also bounded and conservative.

#### 4. Composition of Augmented Marked Graphs

This section first describes the composition of augmented marked graphs via common resource places. Preservation of properties are then studied.

**Property 4.1.** Let  $(N_1, M_{10}; R_1)$  and  $(N_2, M_{20}; R_2)$  be augmented marked graphs, where  $R_1' = \{ r_{11}, r_{12}, \dots, r_{1k} \} \in R_1$  and  $R_2' = \{ r_{21}, r_{22}, \dots, r_{2k} \} \in R_2$  are the common places that  $r_{11}$  and  $r_{21}$  are to be fused into one single place  $r_1$ ,  $r_{12}$  and  $r_{22}$  into  $r_2, \dots, r_{1k}$  and  $r_{2k}$  into  $r_k$ . Then, the net obtained after the fusion is also an augmented marked graph  $(N, M_0; R)$ , where  $R = (R_1 \setminus R_1') \cup (R_2 \setminus R_2') \cup \{ r_1, r_2, \dots, r_k \}$  (obvious).

**Definition 4.1.** With reference to Property 4.1,  $(N, M_0; R)$  is called the composite augmented marked graph of  $(N_1, M_{10}; R_1)$  and  $(N_2, M_{20}; R_2)$  via a set of common resource places  $\{ (r_{11}, r_{21}), (r_{12}, r_{22}), \dots, (r_{1k}, r_{2k}) \}$ , where  $r_{11}, r_{12}, \dots, r_{1k} \in R_1$  and  $r_{21}, r_{22}, \dots, r_{2k} \in R_2$ .  $R_F = \{ r_1, r_2, \dots, r_k \}$  is called the set of fused resource places that are obtained after the fusion of  $(r_{11}, r_{21}), (r_{12}, r_{22}), \dots, (r_{1k}, r_{2k})$ .

Figure 3 shows two augmented marked graphs  $(N_1, M_{10}; R_1)$  and  $(N_2, M_{20}; R_2)$ . Figure 4 shows the composite augmented marked graph  $(N, M_0; R)$  of  $(N_1, M_{10}; R_1)$  and  $(N_2, M_{20}; R_2)$  via  $\{ (r_{11}, r_{21}) \}$ .

**Property 4.2** [5, 6]. Let  $(N, M_0; R)$  be the composite augmented marked graph of two augmented marked graphs  $(N_1, M_{10}; R_1)$  and  $(N_2, M_{20}; R_2)$  via common resource places.  $(N, M_0; R)$  is bounded if and only if  $(N_1, M_{10}; R_1)$  and  $(N_2, M_{20}; R_2)$  are bounded.

**Property 4.3** [6]. Let  $(N, M_0; R)$  be the composite augmented marked graphs of two augmented marked graphs  $(N_1, M_{10}; R_1)$  and  $(N_2, M_{20}; R_2)$  via common resource places.  $(N, M_0; R)$  is conservative if and only if  $(N_1, M_{10}; R_1)$  and  $(N_2, M_{20}; R_2)$  are conservative.

**Definition 4.2.** Let  $(N, M_0; R)$  be the composite augmented marked graph of two augmented marked graphs via common resource places, and  $R_F \subseteq R$  be the set of fused resource places. For  $(N, M_0; R)$ , a

minimal siphon is called a  $R_F$ -siphon if and only if it contains at least one place in  $R_F$ .

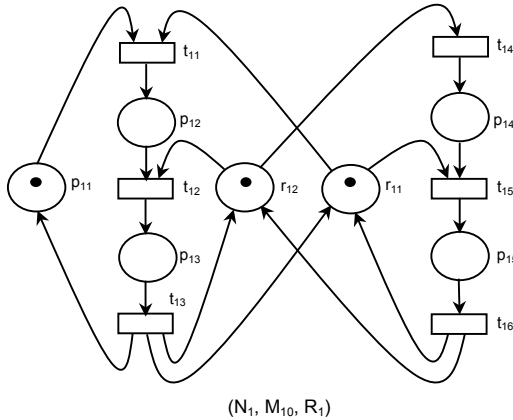

Figure 3. Two augmented marked graphs  $(N_1, M_{10}, R_1)$  and  $(N_2, M_{20}, R_2)$

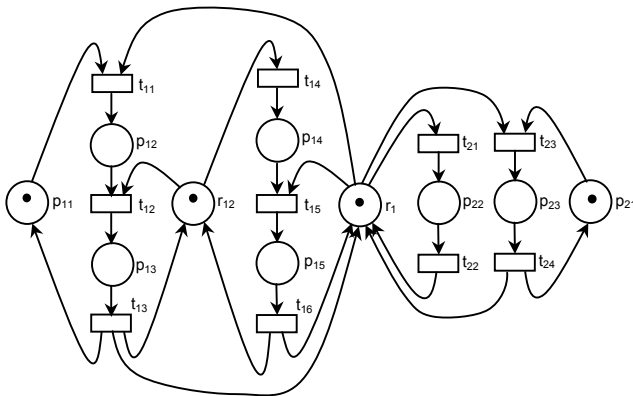

Figure 4. An augmented marked graph obtained by composing the augmented marked graphs in Figure 3 via  $\{r_{11}, r_{21}\}$

**Property 4.4** [6]. Let  $(N, M_0; R)$  be the composite augmented marked graph of two augmented marked graphs  $(N_1, M_{10}; R_1)$  and  $(N_2, M_{20}; R_2)$  via common resource places.  $(N, M_0; R)$  is live and reversible if and only if  $(N_1, M_{10}; R_1)$  and  $(N_2, M_{20}; R_2)$  are live and no  $R_F$ -siphons eventually become empty.

Consider the augmented marked graphs  $(N_1, M_{10}; R_1)$  and  $(N_2, M_{20}; R_2)$  in Figure 3.  $(N_1, M_{10}; R_1)$  is neither live nor reversible but is bounded and conservative.  $(N_2, M_{20}; R_2)$  is live, bounded, reversible and conservative. According to Properties 4.2 and 4.3, the composite augmented marked graph  $(N, M_0; R)$  as shown in Figure 4 is bounded and conservative.

According to Property 4.4,  $(N, M_0; R)$  is neither live nor reversible.

Figure 5 shows another two augmented marked graphs  $(N_1, M_{10}; R_1)$  and  $(N_2, M_{20}; R_2)$ . Figure 6 shows the composite augmented marked graph  $(N, M_0; R)$  of  $(N_1, M_{10}; R_1)$  and  $(N_2, M_{20}; R_2)$  via  $\{r_{11}, r_{21}, r_{12}, r_{22}\}$ . Both  $(N_1, M_{10}; R_1)$  and  $(N_2, M_{20}; R_2)$  are live, bounded, reversible and conservative. No  $R$ -siphons in  $(N, M_0; R)$  would eventually become empty. According to Properties 4.2, 4.3 and 4.4,  $(N, M_0; R)$  is live, bounded, reversible and conservative.

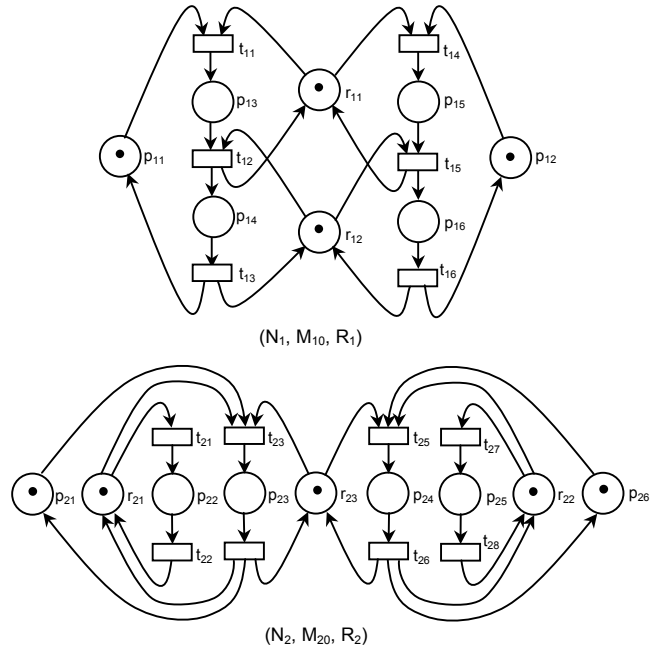

Figure 5. Another two augmented marked graphs  $(N_1, M_{10}, R_1)$  and  $(N_2, M_{20}, R_2)$

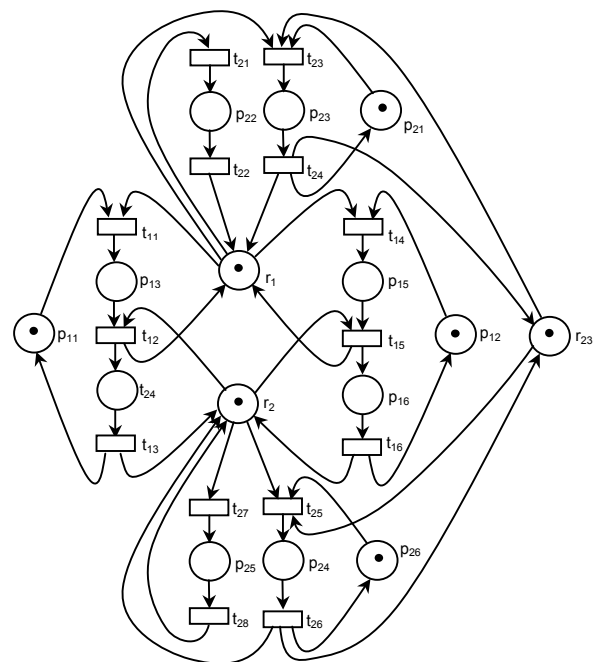

Figure 6. An augmented marked graph obtained by composing the augmented marked graphs in Figure 5 via  $\{r_{11}, r_{21}, r_{12}, r_{22}\}$

### 5. Component-Based System Design

In component-based system design, a system is synthesised from a set of components [10, 11]. The integrated system may not be live and reversible even if all the components are live and reversible, especially as there involves common resources.

By modelling the components as augmented marked graphs and composing them via common resource places, based on the results obtained in the previous section, the properties of the integrated system can be readily derived. In brief, if the components are bounded and conservative, the integrated system will be bounded and conservative. If the components are live and reversible, the integrated system will be live and reversible under a pretty simple condition. These are illustrated in the following two examples.

**Example 1.** It is a FWS-200 Flexible Workstation System for production of circuit boards, extracted from [12] (pp. 121-124). The system consists of two robots B<sub>1</sub> and B<sub>2</sub>, one feeder area and one PCB area, as shown in Figure 7. There are two components :

Component 1 (production of circuit boards by B<sub>1</sub>). This component involves B<sub>1</sub>, feeder area and PCB area. B<sub>1</sub> picks components from the feeder area, and moves into the PCB area for inserting components. The product is then moved out from the PCB area.

Component 2 (production of circuit boards by B<sub>2</sub>). This component involves B<sub>2</sub>, feeder area and PCB area. B<sub>2</sub> picks components from the feeder area, and moves into the PCB area for inserting components. The product is then moved out from the PCB area.

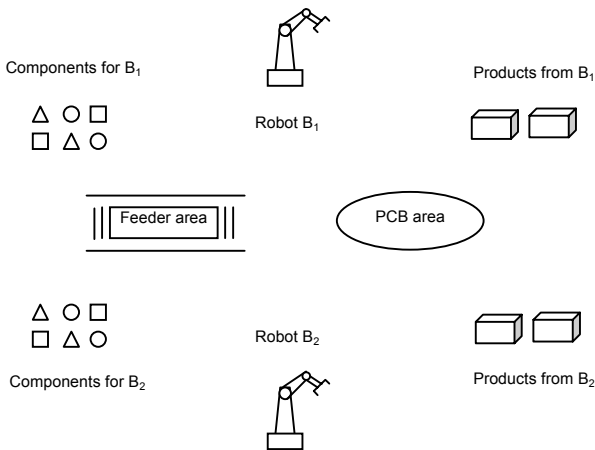

Figure 7. Flexible Workstation System (Example 1)

Components 1 and 2 are modelled as augmented marked graphs  $(N_1, M_{10}; R_1)$  and  $(N_2, M_{20}; R_2)$ , respectively. Figure 8 shows  $(N_1, M_{10}; R_1)$  and  $(N_2, M_{20}; R_2)$ . Both  $(N_1, M_{10}; R_1)$  and  $(N_2, M_{20}; R_2)$  are live, bounded, reversible and conservative.

Common resource places  $r_{11}$  in  $(N_1, M_{10}; R_1)$  and  $r_{21}$  in  $(N_2, M_{20}; R_2)$  refer to the feeder area, and  $r_{12}$  in  $(N_1, M_{10}; R_1)$  and  $r_{22}$  in  $(N_2, M_{20}; R_2)$  refer to the PCB area.  $(N_1, M_{10}; R_1)$  and  $(N_2, M_{20}; R_2)$  are composed via

their common resource places. These common resource places are fused as follows. Places  $r_{11}$  and  $r_{21}$  are fused as  $r_1$ , and  $r_{21}$  and  $r_{22}$  as  $r_2$ . Figure 9 shows the composite augmented marked graph  $(N, M_0; R)$  of  $(N_1, M_{10}; R_1)$  and  $(N_2, M_{20}; R_2)$  via  $\{(r_{11}, r_{21}), (r_{12}, r_{22})\}$ . Since  $(N_1, M_{10}; R_1)$  and  $(N_2, M_{20}; R_2)$  are live, bounded, reversible and conservative, according to Properties 4.2 and 4.3,  $(N, M_0; R)$  is bounded and conservative. For  $(N, M_0; R)$ , no  $R_F$ -siphons would eventually become empty. According to Property 4.4,  $(N, M_0; R)$  is live and reversible.

$(N, M_0; R)$  serves to represent the integrated system. It can be concluded that the Flexible Workstation System is live, bounded, reversible and conservative.

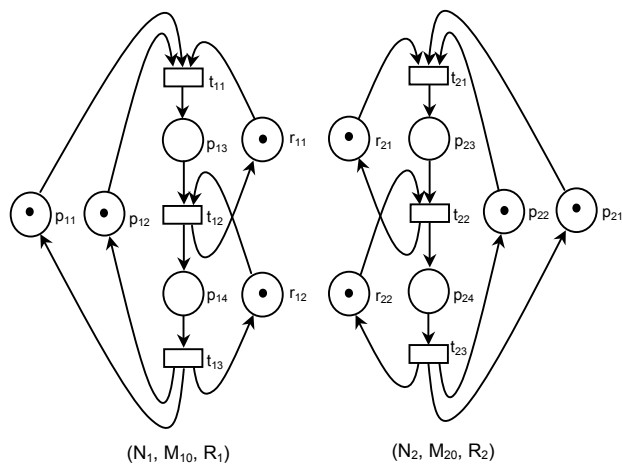

Semantic meaning for places and transitions

- $p_{11}$  B<sub>1</sub> is ready
- $p_{12}$  Components for B<sub>1</sub> are available
- $p_{13}$  B<sub>1</sub> is picking components from feeder
- $p_{14}$  B<sub>1</sub> is inserting components in PCB area
- $p_{21}$  B<sub>2</sub> is ready
- $p_{22}$  Components for B<sub>2</sub> are available
- $p_{23}$  B<sub>2</sub> is picking components from feeder
- $p_{24}$  B<sub>2</sub> is inserting components in PCB area
- $r_{11}$  Feeder area is available
- $r_{12}$  PCB area is available
- $r_{21}$  Feeder area is available
- $r_{22}$  PCB area is available
- $t_{11}$  B<sub>1</sub> starts picking components
- $t_{12}$  B<sub>1</sub> finishes picking components and starts inserting components
- $t_{13}$  B<sub>1</sub> finishes inserting components and starts moving out the product
- $t_{21}$  B<sub>2</sub> starts picking components
- $t_{22}$  B<sub>2</sub> finishes picking components and starts inserting components
- $t_{23}$  B<sub>2</sub> finishes inserting components and starts out the finished product

Figure 8. Specification of system components as augmented marked graphs (Example 1)

**Example 2.** It is a flexible assembly system, comprising four conveyors (C<sub>1</sub>, C<sub>2</sub>, C<sub>3</sub> and C<sub>4</sub>) and four robots (B<sub>1</sub>, B<sub>2</sub>, B<sub>3</sub> and B<sub>4</sub>), as shown in Figure 10. There are four components :

Component 1 (assembly job performed by B<sub>1</sub>). This component involves C<sub>1</sub>, B<sub>1</sub> and B<sub>2</sub>. C<sub>1</sub> requests

B<sub>1</sub> and B<sub>2</sub> simultaneously. On acquiring B<sub>1</sub> and B<sub>2</sub>, it performs assembly and then releases B<sub>1</sub> and B<sub>2</sub> on completion.

Component 2 (assembly job performed by B<sub>2</sub>). This component involves C<sub>2</sub>, B<sub>2</sub> and B<sub>3</sub>. C<sub>2</sub> requests B<sub>2</sub> and B<sub>3</sub> simultaneously. On acquiring B<sub>2</sub> and B<sub>3</sub>, it performs assembly and then releases B<sub>2</sub> and B<sub>3</sub> on completion.

Component 3 (assembly job performed by B<sub>3</sub>). This component involves C<sub>3</sub>, B<sub>3</sub> and B<sub>4</sub>. C<sub>3</sub> requests B<sub>3</sub> and B<sub>4</sub> simultaneously. On acquiring B<sub>3</sub> and B<sub>4</sub>, it performs assembly and then releases B<sub>3</sub> and B<sub>4</sub> on completion.

Component 4 (assembly performed by B<sub>4</sub>). This component involves C<sub>4</sub>, B<sub>4</sub> and B<sub>1</sub>. C<sub>4</sub> requests B<sub>4</sub> and B<sub>1</sub> simultaneously. On acquiring B<sub>4</sub> and B<sub>1</sub>, it performs assembly and then releases B<sub>4</sub> and B<sub>1</sub> on completion.

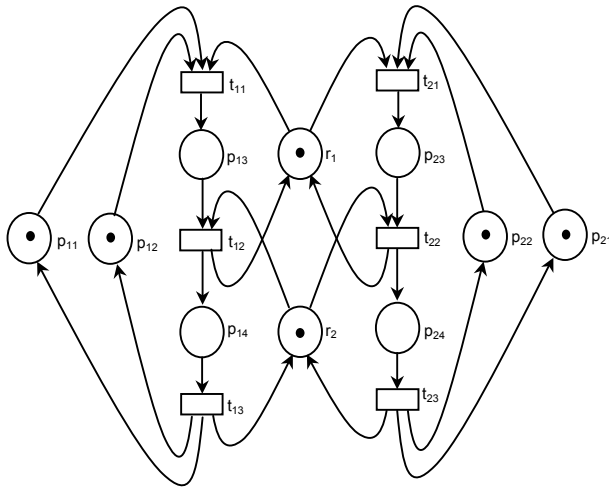

Semantic meaning for places and transitions

- p<sub>11</sub> B<sub>1</sub> is ready
- p<sub>12</sub> Components for B<sub>1</sub> are available
- p<sub>13</sub> B<sub>1</sub> is picking components from feeder
- p<sub>14</sub> B<sub>1</sub> is inserting components in PCB area
- p<sub>21</sub> B<sub>2</sub> is ready
- p<sub>22</sub> Components for B<sub>2</sub> are available
- p<sub>23</sub> B<sub>2</sub> is picking components from feeder
- p<sub>24</sub> B<sub>2</sub> is inserting components in PCB area
- r<sub>1</sub> Feeder area is available
- r<sub>2</sub> PCB area is available
- t<sub>11</sub> B<sub>1</sub> starts picking components
- t<sub>12</sub> B<sub>1</sub> finishes picking components and starts inserting components
- t<sub>13</sub> B<sub>1</sub> finishes inserting components and starts moving out the product
- t<sub>21</sub> B<sub>2</sub> starts picking components
- t<sub>22</sub> B<sub>2</sub> finishes picking components and starts inserting components
- t<sub>23</sub> B<sub>2</sub> finishes inserting components and starts out the finished product

**Figure 9.** An augmented marked graph obtained by composing the augmented marked graphs in Figure 8 via { (r<sub>11</sub>, r<sub>21</sub>), (r<sub>12</sub>, r<sub>22</sub>) } (Example 1)

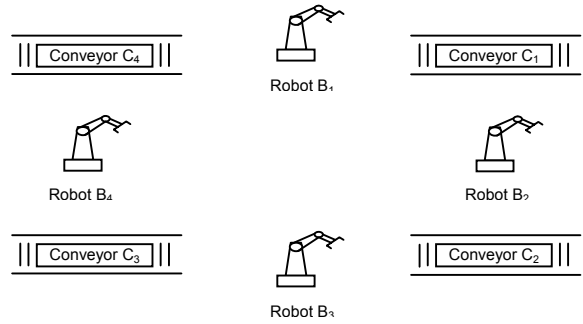

**Figure 10.** Flexible Assembly System (Example 2)

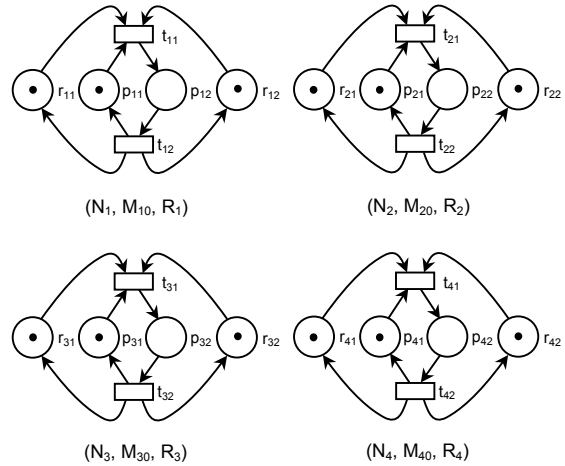

Semantic meaning for places and transitions

- p<sub>11</sub> C<sub>1</sub> is ready
- p<sub>12</sub> C<sub>1</sub> is occupying B<sub>1</sub> and B<sub>2</sub> and performing assembly
- p<sub>21</sub> C<sub>2</sub> is ready
- p<sub>22</sub> C<sub>2</sub> is occupying B<sub>2</sub> and B<sub>3</sub> and performing assembly
- p<sub>31</sub> C<sub>3</sub> is ready
- p<sub>32</sub> C<sub>3</sub> is occupying B<sub>3</sub> and B<sub>4</sub> and performing assembly
- p<sub>41</sub> C<sub>4</sub> is ready
- p<sub>42</sub> C<sub>4</sub> is occupying B<sub>4</sub> and B<sub>1</sub> and performing assembly
- r<sub>11</sub> B<sub>1</sub> is available
- r<sub>12</sub> B<sub>2</sub> is available
- r<sub>21</sub> B<sub>2</sub> is available
- r<sub>22</sub> B<sub>3</sub> is available
- r<sub>31</sub> B<sub>3</sub> is available
- r<sub>32</sub> B<sub>4</sub> is available
- r<sub>41</sub> B<sub>4</sub> is available
- r<sub>42</sub> B<sub>1</sub> is available
- t<sub>11</sub> C<sub>1</sub> acquires B<sub>1</sub> and B<sub>2</sub> and starts assembly
- t<sub>12</sub> C<sub>1</sub> finishes assembly and releases B<sub>1</sub> and B<sub>2</sub>
- t<sub>21</sub> C<sub>2</sub> acquires B<sub>2</sub> and B<sub>3</sub> and starts assembly
- t<sub>22</sub> C<sub>2</sub> finishes assembly and releases B<sub>2</sub> and B<sub>3</sub>
- t<sub>31</sub> C<sub>3</sub> acquires B<sub>3</sub> and B<sub>4</sub> and starts assembly
- t<sub>32</sub> C<sub>3</sub> finishes assembly and releases B<sub>3</sub> and B<sub>4</sub>
- t<sub>41</sub> C<sub>4</sub> acquires B<sub>4</sub> and B<sub>1</sub> and starts assembly
- t<sub>42</sub> C<sub>4</sub> finishes assembly and releases B<sub>4</sub> and B<sub>1</sub>

**Figure 11.** Specification of system components as augmented marked graphs (Example 2)

Components 1, 2, 3 and 4 are modelled as augmented marked graphs  $(N_1, M_{10}; R_1)$ ,  $(N_2, M_{20}; R_2)$ ,  $(N_3, M_{30}; R_3)$  and  $(N_4, M_{40}; R_4)$ , respectively. Figure 11 shows these augmented marked graphs. They are live, bounded, reversible and conservative.

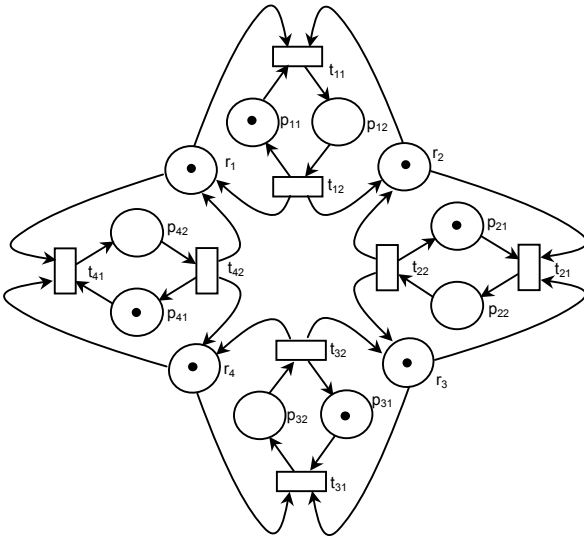

#### Semantic meaning for places and transitions

$p_{11}$	C1 is ready
$p_{12}$	C1 is occupying B1 and B2 and performing assembly
$p_{21}$	C2 is ready
$p_{22}$	C2 is occupying B2 and B3 and performing assembly
$p_{31}$	C3 is ready
$p_{32}$	C3 is occupying B3 and B4 and performing assembly
$p_{41}$	C4 is ready
$p_{42}$	C4 is occupying B4 and B1 and performing assembly
$r_1$	B1 is available
$r_2$	B2 is available
$r_3$	B3 is available
$r_4$	B4 is available
$t_{11}$	C1 acquires B1 and B2 and starts assembly
$t_{12}$	C1 finishes assembly and releases B1 and B2
$t_{21}$	C2 acquires B2 and B3 and starts assembly
$t_{22}$	C2 finishes assembly and releases B2 and B3
$t_{31}$	C3 acquires B3 and B4 and starts assembly
$t_{32}$	C3 finishes assembly and releases B3 and B4
$t_{41}$	C4 acquires B4 and B1 and starts assembly
$t_{42}$	C4 finishes assembly and releases B4 and B1

**Figure 12.** An augmented marked graph obtained by composing the augmented marked graphs in Figure 11 via  $\{(r_{11}, r_{42}), (r_{12}, r_{21}), (r_{22}, r_{31}), (r_{32}, r_{41})\}$ . (Example 2)

Common resource places  $r_{12}$  in  $(N_1, M_{10}; R_1)$  and  $r_{21}$  in  $(N_2, M_{20}; R_2)$  refer to  $B_2$ . Common resource places  $r_{22}$  in  $(N_2, M_{20}; R_2)$  and  $r_{31}$  in  $(N_3, M_{30}; R_3)$  refer

to  $B_3$ . Common resource places  $r_{32}$  in  $(N_3, M_{30}; R_3)$  and  $r_{41}$  in  $(N_4, M_{40}; R_4)$  refer to  $B_4$ . Common resource places  $r_{42}$  in  $(N_4, M_{40}; R_4)$  and  $r_{11}$  in  $(N_1, M_{10}; R_1)$  refer to  $B_1$ .

$(N_1, M_{10}; R_1)$ ,  $(N_2, M_{20}; R_2)$ ,  $(N_3, M_{30}; R_3)$  and  $(N_4, M_{40}; R_4)$  are composed via their common resource places. These common resource places are fused as follows. Places  $r_{12}$  and  $r_{21}$  are fused together as  $r_2$ ,  $r_{22}$  and  $r_{31}$  as  $r_3$ ,  $r_{32}$  and  $r_{41}$  as  $r_4$ , and  $r_{42}$  and  $r_{11}$  as  $r_1$ . Figure 12 shows the composite augmented marked graph  $(N, M_0; R)$  of  $(N_1, M_{10}; R_1)$ ,  $(N_2, M_{20}; R_2)$ ,  $(N_3, M_{30}; R_3)$  and  $(N_4, M_{40}; R_4)$  via  $\{(r_{11}, r_{42}), (r_{12}, r_{21}), (r_{22}, r_{31}), (r_{32}, r_{41})\}$ .

Since  $(N_1, M_{10}; R_1)$ ,  $(N_2, M_{20}; R_2)$ ,  $(N_3, M_{30}; R_3)$  and  $(N_4, M_{40}; R_4)$  are live, bounded, reversible and conservative, according to Properties 4.2 and 4.3,  $(N, M_0; R)$  is bounded and conservative. For  $(N, M_0; R)$ , no  $R_F$ -siphons would eventually become empty. According to Property 4.4,  $(N, M_0; R)$  is live and reversible.

$(N, M_0; R)$  serves to represent the integrated system. It can be concluded that the Flexible Assembly System is live, bounded, reversible and conservative.

## 6. Conclusion

This paper describes the composition of augmented marked graphs via common resource places, where preservation of properties (including liveness, boundedness, reversibility and conservativeness) is thoroughly investigated.

It is shown that, for this composition, boundedness and conservativeness are preserved while liveness and reversibility can be preserved under a pretty simple condition. We then show its application to component-based system design. By modelling the system components as augmented marked graphs with their common resources denoted by common resource places, an integrated system can be obtained by composing these augmented marked graphs via these common resource places. Then, based on the preservation of properties, liveness, boundedness, reversibility and conservativeness of the integrated system can be readily derived from its components.

In system engineering, liveness, boundedness, reversibility and conservativeness are essential properties that collectively refer to the robustness and well-behavedness of a system. Hence, in synthesising a system from its components, it is important to assure that these essential system properties can be preserved, especially as there involves shared resources wherein erroneous situations such as deadlocks and capacity overflows can be easily induced. The composition of augmented marked graphs proposed in this paper contributes to component-based system design to provide a means of building a system from its components, where the essential system properties can be effectively analysed. These are illustrated with examples of manufacturing system integration.

## 7. References

- [1] **F. Chu and X. Xie.** Deadlock Analysis of Petri Nets Using Siphons and Mathematical Programming. *IEEE Transactions on Robotics and Automation*, Vol.13, No.6, 1997, 793-804.
- [2] **K.S. Cheung.** New Characterisations for Live and Reversible Augmented Marked Graphs. *Information Processing Letters*, Vol. 92, No. 5, 2004, 239-243.
- [3] **K.S. Cheung and K.O. Chow.** Cycle Inclusion Property of Augmented Marked Graphs. *Information Processing Letters*, Vol. 94, No. 6, 2005, 271-276.
- [4] **K.S. Cheung.** Boundedness and Conservativeness of Augmented Marked Graphs. *IMA Journal of Mathematical Control and Information*, Oxford University Press, Vol. 24, No.2, 2007, 235-244.
- [5] **H.J. Huang, L. Jiao, T.Y. Cheung.** Property-Preserving Composition of Augmented Marked Graphs that Share Common Resources. *Proceedings of the IEEE International Conference on Robotics and Automation*, Vol.1, IEEE Press, 2003, 1446-1451.
- [6] **K.S. Cheung, K.O. Chow.** Compositional Synthesis of Augmented Marked Graphs. *Proceedings of the IEEE International Conference on Control and Automation*, IEEE Press, 2007, 2810-2814.
- [7] **W. Reisig.** Petri Nets: An Introduction. *Springer*, 1985.
- [8] **T. Murata.** Petri Nets: Properties, Analysis and Applications. *Proceedings of the IEEE*, Vol.77, No.4, 1989, 541-580.
- [9] **J. Desel, W. Reisig.** Place Transition Petri Nets, Lectures on Petri Nets, Volume 1 : Basic Models. *Lecture Notes in Computer Science*, Vol.1491, Springer-Verlag, 1998, pp. 122-173.
- [10] **G.T. Heineman, W.T. Councill.** Component-Based Software Engineering : Putting the Pieces Together. *Addison-Wesley*, 2002.
- [11] **I. Crnkovic, M. Larsson.** Building Reliable Component-Based Software Systems. *Artech House*, 2002.
- [12] **M.C. Zhou, K. Venkatesh.** Modeling, Simulation and Control of Flexible Manufacturing Systems : A Petri Net Approach. *World Scientific*, 1999.

Received June 2007.

DOI: 10.5755/j01.itc.36.3.11877