

# APPLICATION OF KALMAN FILTER ALGORITHMS IN A GMC CONTROL STRATEGY FOR FED-BATCH CULTIVATION PROCESS

Ana Alvarez, Rimydas Simutis

*Process Control Department, Kaunas University of Technology  
Studentų g. 50, LT-3031 Kaunas, Lithuania*

**Abstract.** This paper addresses the study of a Generic Model Control (GMC) approach for regulation of the specific growth rate of for fed-batch cultivation process. This approach requires all the process states to be available on line. Since direct measurement of these states is not possible, a state estimator must be implemented. In this work, the estimator is a Kalman filter that uses the oxygen uptake rate (OUR) of the microorganisms as the measurable process output. Another practical issue constitutes the time delay present in the OUR measurements, a Smith predictor compensation is proposed to overcome this problem. Several simulations were carried out to test this scheme using an experimentally identified process model.

**Key words:** Kalman filter, generic model control, fed-batch culture.

## 1. Introduction

The automatic control of the specific growth rate in cell cultivation processes has become a major issue in process control in the recent years. One of the important applications of advanced specific growth rate control schemes is the production of recombinant proteins for pharmaceuticals. The bacterium *Escherichia coli*, with glucose as energy source, is frequently used as a host organism for recombinant protein production. A technical problem that may be encountered during this process is the formation of acetates by high growth rate of microorganisms that can inhibit cell growth during the cultivation. Because of this fact, the implementation of a reliable control scheme for the specific growth rate becomes mandatory [2,7].

Several control schemes for fed-batch bioprocess have been investigated up to this date, a good compendium of them can be found in [7].

One of the possible control approaches is the use of model based control schemes [6].

In this paper one of them, known as Generic Model Control (GMC), [4,5] is investigated. In this theory, the nonlinear model process is directly embedded in the control law. One of the major drawbacks, however, is the need to have all the states of the process available on-line to calculate the control law. The lack of instrumentation to measure the values of the variables that characterize the process, such as substrate or biomass concentration, makes it necessary to use software sensors that can estimate the states using the on-line measurements available. A

commonly used measurement is the oxygen uptake rate (OUR). In addition, the time delay present in the OUR measurement represents another practical problem. The solution proposed, is to compensate this measurement with the aid of a Smith predictor [9]. In this work, a MATLAB/SIMULINK simulation tools was implemented to test the proposed estimation and control scheme. A table is provided comparing the integrated square error (ISE) of control algorithm for different values of estimated time delay in the Smith predictor and also for cases without time delay, and with uncompensated time delay.

The paper covers an overview of the GMC theory, an introduction to the mathematical model of the process, a description of the implementation of the Kalman filter with Smith predictor, and finally the simulation results and conclusions.

## 2. Generic model control theory

The generic model control approach is a theory that incorporates the process model directly in the control law, it has the distinctive characteristic that it solves an optimisation problem in only one step of calculation [4,5]. This section shows the basics of the theory.

Suppose a process is described by equations (1) and (2):

$$\dot{\mathbf{x}} = \mathbf{f}(\mathbf{x}, \mathbf{u}, \mathbf{d}, t) \quad (1)$$

$$\mathbf{y} = \mathbf{g}(\mathbf{x}) \quad (2)$$

Where  $\mathbf{x}$  is the state vector with dimension  $n$ ,  $\mathbf{u}$  is the manipulated variable and has dimension  $m$ ,  $\mathbf{d}$  is the vector of disturbances with dimension  $l$ ,  $\mathbf{y}$  is the vector of measurements with dimension  $p$ .

In the general case, both  $\mathbf{f}$  and  $\mathbf{g}$  are nonlinear functions.

The classical approach in feedback control is to compare a set-point desired for the output with its actual value, in order to form an error signal to be given as input to the controller.

In Generic Model Control, this error signal is also formed, but *the control objective is expressed in terms of the value of the derivative of the output*. The control scheme calculates the manipulated variable vector so that the derivative of the output follows an established pattern. To get the expression of this pattern, it must be considered that, when the error signal is zero, we want the system to remain steady (with null derivative), when the output is less than the set-point we want the system to increase the output (positive derivative) and when the output value is greater than the set-point we want the output to decrease.

So, it is desirable that the rate of change in the output to be proportional to the error signal. In addition, to have zero error in steady state, the output should also change its value in presence of an integral error. All these qualitative considerations lead to a desired expression for the system's output derivative as seen in equation (3):

$$\dot{\mathbf{y}}_{system} = \mathbf{K}_1 (\mathbf{y}_{setpoint} - \mathbf{y}) + \mathbf{K}_2 \int (\mathbf{y}_{setpoint} - \mathbf{y}) dt \quad (3)$$

Where  $\mathbf{K}_1$  and  $\mathbf{K}_2$  are diagonal matrices that can be made to vary with time. The values for  $\mathbf{K}_1$  and  $\mathbf{K}_2$  must be determined during tuning procedures.

The manipulated vector  $\mathbf{u}(t)$  must be determined in order that the system follows (3) as closely as possible. Therefore the optimal control problem can be formulated as follow:

Using the model equations

$$\begin{aligned} \dot{\mathbf{x}} &= \mathbf{f}(\mathbf{x}, \mathbf{u}, \mathbf{d}, t) \\ \mathbf{y} &= \mathbf{g}(\mathbf{x}) \end{aligned}$$

it is necessary to find a control profile  $\mathbf{u}(t)$ ,  $|\mathbf{u}(t)| \leq \alpha$ , which minimize the criteria

$$\int_0^{t_f} [\mathbf{h}(\mathbf{x}, \mathbf{u}, \mathbf{d}, t)^T \mathbf{W} \mathbf{h}(\mathbf{x}, \mathbf{u}, \mathbf{d}, t)] dt, \quad (4)$$

where  $\mathbf{W}$  is a positive weighting matrix and

$$\begin{aligned} \mathbf{h}(\mathbf{x}, \mathbf{u}, \mathbf{d}, t) &= \dot{\mathbf{y}} - \dot{\mathbf{y}}_{system}, \text{ OR} \\ \mathbf{h}(\mathbf{x}, \mathbf{u}, \mathbf{d}, t) &= \\ \frac{\partial \mathbf{g}}{\partial \mathbf{x}} \mathbf{f}(\mathbf{x}, \mathbf{u}, \mathbf{d}, t) - \mathbf{K}_1 (\mathbf{y}_{setpoint} - \mathbf{y}) - \mathbf{K}_2 \int (\mathbf{y}_{setpoint} - \mathbf{y}) dt \end{aligned} \quad (5),$$

if we estimate the derivative of the system's output  $\dot{\mathbf{y}}$  using the equations (1) and (2)

$$\dot{\mathbf{y}} = \frac{\partial \mathbf{g}}{\partial \mathbf{x}} \mathbf{f}(\mathbf{x}, \mathbf{u}, \mathbf{d}, t). \quad (6)$$

Now it is easy to become an analytical solution for optimal control profile  $\mathbf{u}(t)$  using equation (4) and (5). A complete solution of this task can be found in [4, 5].

### 3. Practical aspects of the control algorithm

#### 3.1. System identification

Several experiments were carried out in a bio-reactor, the data sets obtained from online and offline measurements were used to identify the parameters of a model with the structure of equations (8) to (11), using also the Monod equation, (12) for the kinetics of the growth rate. The method used for identification was non-linear least squares.

$$\frac{dx_b}{dt} = \mu x_b - \frac{F}{W} x_b \quad (8)$$

$$\frac{ds}{dt} = -\frac{\mu x_b}{Y_{x/s}} + \frac{F}{W} (s_F - s) \quad (9)$$

$$\frac{dW}{dt} = F - F_{ev} \quad (10)$$

$$OUR = \alpha \mu x_b W + \beta x_b W \quad (11)$$

$$\mu = \mu_{max} \frac{s}{K_s + s} \quad (12)$$

The explanation of the parameters and the identified values is featured in Table 1. The explanation of the process variables is featured in Table 2.

**Table 1.** List of identified model parameters

Symbol	Name	Dimensions	Value
$\alpha$	yield biomass/oxygen	g/g	0.82
$\beta$	maintenance term for oxygen	g/g/h	0.01
$s_F$	substrate concentration in feed	g/kg	490.0 (given value)
$\mu_{max}$	maximum growth rate	1/h	0.6589
$K_S$	saturation constant	g/kg	0.0504
$Y_{x/s}$	yield substrate/biomass	g/g	0.4350
$F_{ev}$	Evaporation of medium	kg/h	0.0129

**Table 2.** List of process variables

Symbol	Name	Dimensions
$\mu$	Specific biomass growth rate	1/h
$s$	Substrate concentration	g/kg
$x_b$	Biomass concentration	g/kg
$F$	Feeding rate	kg/h
$W$	Bioreactor weight	kg
OUR	Oxygen uptake rate	g/h

### 3.2. GMC control law

For the case of automatic control of the growth rate, equation (3) becomes equation (13).

$$\frac{\partial \mu}{\partial t} = K_1(\mu_{\text{setpoint}} - \mu) + K_2 \int (\mu_{\text{setpoint}} - \mu) dt \quad (13)$$

The time derivative of the growth rate can be obtained by the chain rule as featured in equation (14).

$$\frac{\partial \mu}{\partial t} = \frac{\partial \mu}{\partial s} \frac{\partial s}{\partial t} = \mu_{\text{max}} \frac{K_s}{(K_s + s)^2} \frac{\partial s}{\partial t} \quad (14)$$

Substituting eq. (9) into eq. (14) and operating with eq.(13) gives:

$$F = (Y_{s/x} \mu x + (K_1(\mu_{\text{setpoint}} - \mu) + K_2 \int (\mu_{\text{setpoint}} - \mu) dt) \frac{(K_s + s)^2}{\mu_{\text{max}} K_s}) \frac{W}{(s_F - s)} \quad (15)$$

### 3.3. Kalman Filtering Scheme

In order to implement the control law featured in eq.(15), all the states of the process, and also an estimation of the growth rate must be available to perform online calculations. For this purpose, the control scheme with the Kalman filter algorithms [3,8,10] as featured in Figure 1 was investigated. The Kalman filter makes the prediction of the states in such way that the variance of the prediction error is minimized.

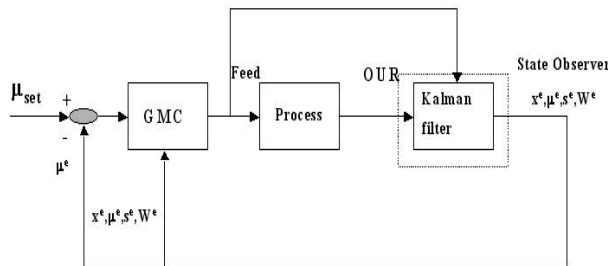
**Figure 1.** Block diagram of the control algorithm

To implement it, the process represented by Eqs. (8) to (10) is considered to be of the general structure of Eq. (16).

$$\frac{dy}{dt} = f(\mathbf{y}(t), F(t), \mathbf{N}(t)) \quad (16)$$

Here  $\mathbf{y}$  represents the vector of states  $[x, s, W]$ ,

$F$  the feed rate, and  $\mathbf{N}$  a vector of components of Gaussian noise additive to the states to account for model uncertainty.

The output of the system, the oxygen uptake rate, eq. (11) can be associated to the general form of Eq. (17)

$$\mathbf{z}(t) = \mathbf{h}(\mathbf{y}(t), F(t)) + \mathbf{v}(t) \quad (17)$$

In the previous equation  $\mathbf{v}$  is a vector of Gaussian noise to account for measurement errors.

The details of the implementation of the Kalman Filter can be found, among others in [3,8,10].

In order to implement the Kalman Filter the differential equation of the process model were solved using Euler Method. The sampling time was chosen taking special care in the numerical stability of the method, which, for the values of this particular process, showed to be at risk for values of sampling time  $T \geq 0.005h$ .

The condition of numerical stability is featured in Eq.(18)

$$\left| 1 + T \frac{\partial \mathbf{f}}{\partial \mathbf{y}}(\mathbf{y}_\varepsilon, F_\varepsilon) \right| \leq 1 \quad (18)$$

In (18)  $\mathbf{y}_\varepsilon, F_\varepsilon$  represent intermediate values of the states and the input, respectively, in any given interval between sampling times.

The condition is to be fulfilled in all time intervals of the simulation. Taking this into account, the sampling time was finally set in  $T=0.003h$ .

### 3.4 Time delay treatment

In practice, the measurement of the oxygen uptake rate has a time delay of approximately 2 minutes. This time delay was involved in the process modeling scheme.

Initially, before real information can be obtained for the process, the states are predicted by the mathematical model, when the simulation time equals the time delay, the estimation of states is switched to the Kalman filter.

The Kalman filter estimates the states of the system by the aid of the delayed measurement of the oxygen uptake rate. This case adds to the problems of model mismatch and noise in the OUR signal, also the problem of time delay. The problem of state prediction during initialisation stage offers no major problems because all of them occurs during batch mode of the cultivation.

A Smith predictor in its original configuration [9] is used to compensate the time delay in process control schemes. The proposed configuration produces an estimation of the disturbances due to model mismatching and noise by subtracting the real measurement and the delayed model output. To this

estimation of disturbances, the output of the model, without any delay, is added (Figure 2).

An important design problem is concerned with the robust stability of the Smith Predictor in the presence of model mismatching and uncertainty in the time delay. For the case of linear systems, researches approaching the problem with  $H^\infty$  and frequency domain modern control techniques are known [1, 11].

The scope of this work was only to carry out different simulation experiments to find the possible range of variation in the estimation of time delay, which guarantees the stability of the system.

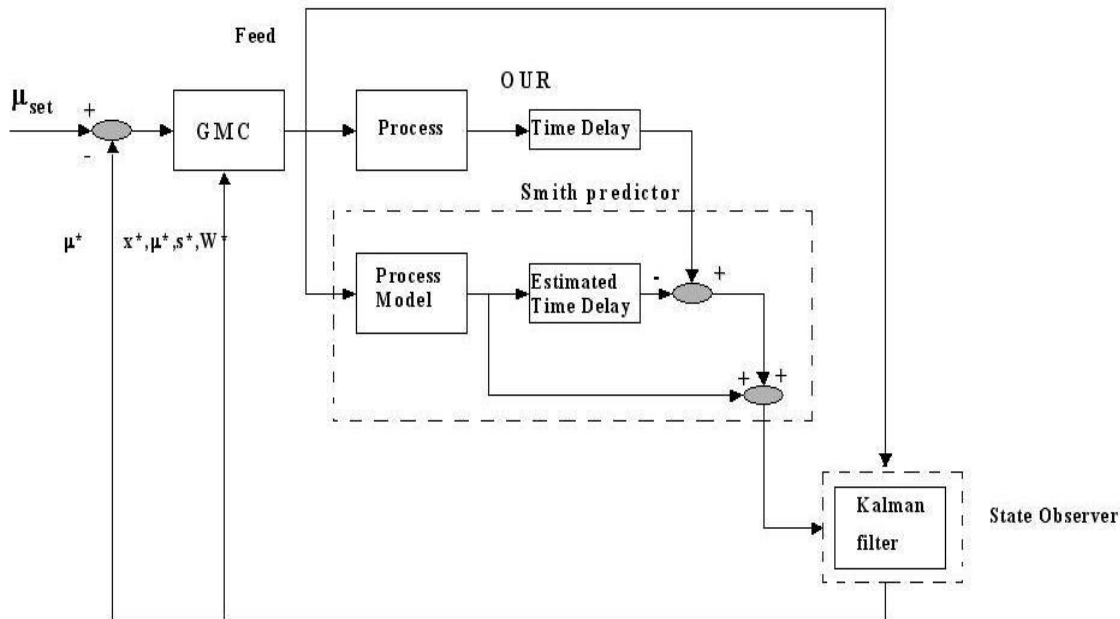

Figure 2. Block diagram of control algorithm with Smith predictor

#### 4. Simulation studies

Four different kinds of simulation, representing a period of 12h were carried out with initial conditions,  $x(0)=0.132\text{g/kg}$  ;  $s(0)=18.8\text{g/kg}$  ;  $W(0)=5.13\text{kg}$ .

Firstly the GMC control law was simulated under conditions of no time delay and conditions of noise and model mismatch. For this purpose, the OUR data were disturbed with Gaussian noise with zero mean and standard deviation of 5 % around the measured values. For every simulation run every model parameter was disturbed with a random number normally distributed with zero mean and standard deviation of 5 % around the original value. An exception was the value of  $\mu_{\max}$ , for this case the standard deviation of the perturbation was 3 %. In order to analyse the method's performance, 10 simulation runs were repeated. A typical controlled profile for the growth rate is featured in Fig.3; the average integrated square error (ISE) of controlled  $\mu$  can be seen in Table 3. It must be pointed out that in programming of the GMC

control law constraints were added to the control signal.

If the calculation of the feed rate goes below zero, then the feed is set to zero, and the state of the integrator is updated to correspond with the new value. The same case occurs if the variation between sampling times of the feed is greater than 50%. This value was taken arbitrarily, and in practice it must be substituted with a value related to the capacity of response of the valve used in the application. A typical profile for the feed rate is featured in Figure 4.

Secondly, a type of simulation corresponding to the non-compensated time delay was performed, a typical profile for the growth rate can be seen in Figure 5.

Finally, simulations with the Smith predictor compensation were carried out. The mismatch in the process parameters was programmed to be the same as in the Kalman filter. The analysed mismatch for the time delay was  $\pm 20\%$  since with greater errors, the

control turned out not to be possible. Results are shown in Figure 6 and Table 3.

The conditions of noise and model mismatch were the same in all four kinds of simulation.

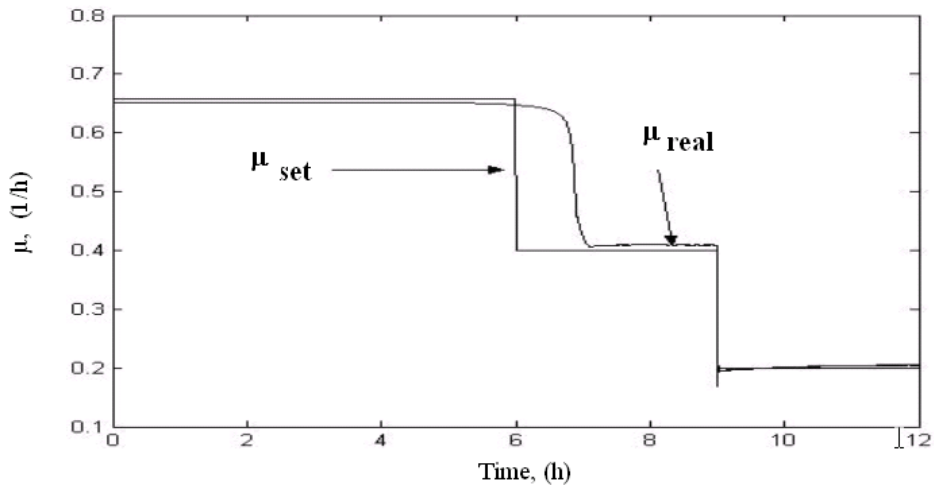

Figure 3. Simulation results without time delay in measurements

Table 3. List of integrated square errors (controlled variable  $\mu$ )

Type of Simulation	Average ISE (10 repetitions of simulation)
No time delay	18.87
2 min time delay, (without Smith predictor)	27.19
2 min time delay, with Smith predictor time delay-20%	24.62
2min time delay, with Smith predictor time delay +20%	19.8

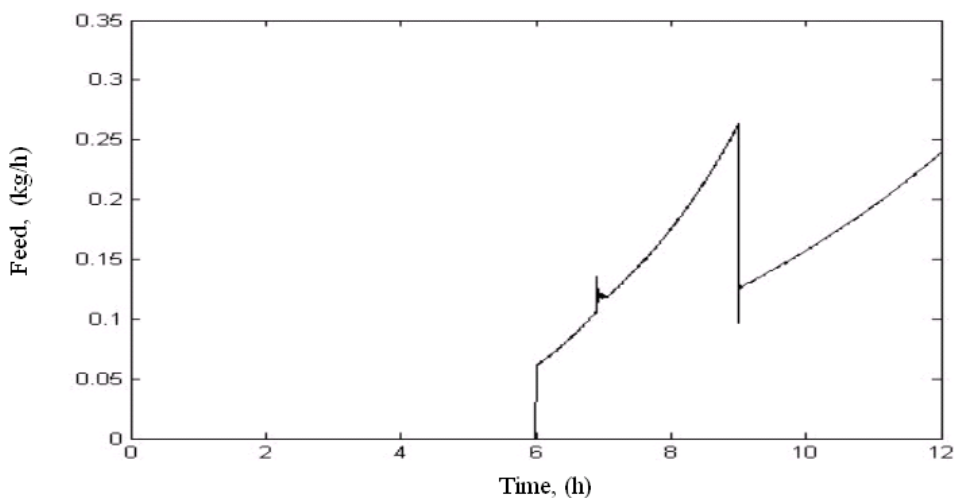

Figure 4. Simulation results for the substrate feed rate (without time delay)

## 5. Results and discussion

From the analysis of Table 3, it can be deduced that with Smith Predictor compensation, from the point of view of the ISE is effective. The performance obtained is similar to that in the non-delay case. The case of an over-estimation of time delay is remarkably better than the sub-estimation case. This is due to the characteristics of the  $\mu$  set-point profile, (a decreasing function of time), and the delayed OUR signal, which increases with time. A big sub-estimation in the time delay will result in a  $\mu$  bigger than the real one, and in the transition from batch to fed- batch process

this error can result in a growth rate that goes far down the desired value without the control counteracting this fact on time.

It must be pointed out that for greater values of errors in the time delay of OUR, it was not possible to get stable values of  $\mu$  estimation.

Another important issue concerns the parameter mismatch. The growth rate was calculated in this work according to equation (12). This equation presents a high sensibility to variations of  $\mu_{max}$ . For the values of  $\mu_{max}$  mismatch greater than 3% the stability of the algorithm is not guaranteed.

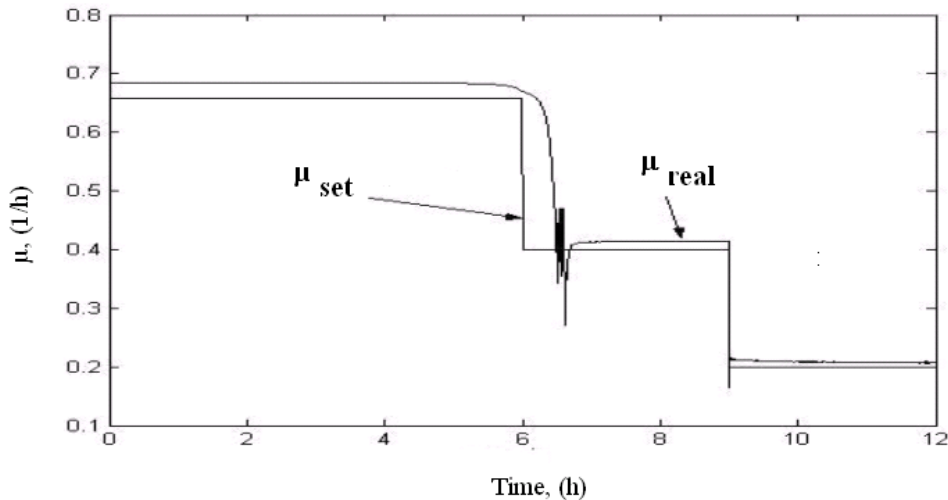

Figure 5. Simulation results with time delay 2 min for OUR (without Smith predictor compensation)

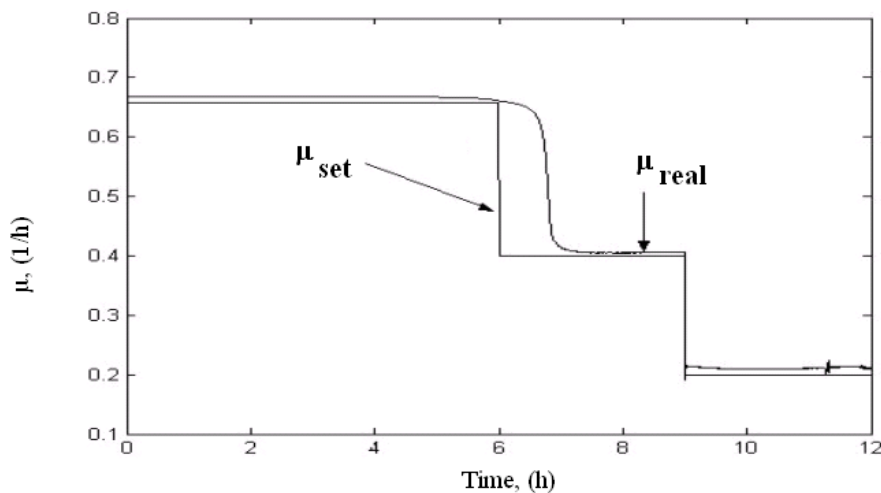

Figure 6. Simulation results with time delay 2 min. for OUR. Smith predictor is used for time delay compensation. (+20% error in time delay estimation,  $K_1=23$ ;  $K_2=420$ )

## References

- [1] E.J. Adam, H.A. Latchman, O.D. Crisalle. Robustness with Respect to Uncertainty in the Time-Delay Parameter. *Proceedings of the American Control Conference, Chicago, Illinois*, 2000.
- [2] M. Åkesson. Probing Control of Glucose Feeding in Escherichia Coli Cultivations. *Wallin & Dalholm Boktryckeri AB, Sweden*, 1999.
- [3] R. Kalman. A New Approach to Linear Filtering and Prediction Problems. *Transactions of the ASME-Journal of Basic Engineering*, 82 (Series D), 1960, 35-45.
- [4] P.L. Lee, G.R. Sullivan. Generic Model Control – Theory and Applications. *IFAC Symposium on Model Based Process Control, Atlanta GA, USA*, 1988
- [5] P.L. Lee, G.R. Sullivan. Generic model control. *Computer and Chem Eng*, Vol. 12(6), 1998, 573-580.
- [6] A. Lübert, R. Simutis. Measurement and Control. *Basic Biotechnology, Cambridge University Press*, 2001
- [7] H. Roubos. Bioprocess Modeling and Optimization. Fed-Batch Clavulanic Acid Production by Streptomyces Clavuligerus. *Ponsen & Looijen, The Netherlands*, 2002.
- [8] G. Siouris. An Engineering approach to estimation theory. *John Wiley & Sons INC*, 1996.
- [9] O.J.M. Smith. Closer Control of Loops with Dead Time, *Chem. Eng. Prog.*, Vol. 53, 1957, 217.
- [10] G. Welch, G. Bishop. An Introduction to the Kalman Filter. *University of North Carolina at Chapel Hill, Department of Computer Science*, 2001
- [11] J. Zhang, P.L. Li. Robust control method of time-delay systems based on Smith predictor. *TENCON '02. Proceedings. 2002 IEEE Region 10 Conference on Computers, Communications, Control and Power Engineering*, v.3, 2002, 1310 -1313.

DOI: 10.5755/j01.itc.30.1.11803